

Theory of Quantum Matter at Monash University



Meera Parish and Jesper Levinsen

About us

• Meera's research is focussed on the theory of strongly correlated phenomena in cold atomic gases and electron systems. Particular topics of interest include low-dimensional quantum systems, superconductivity and quantum impurities. A large part of her work is carried out within the Australian Centre of Excellence for Future Low-Energy Electronics Technologies (FLEET), where she currently leads the theoretical effort on light-matter coupled systems.



Contact: meera.parish@monash.edu

• Jesper's research focusses on strongly interacting quantum systems on the interface between condensed matter physics and the physics of ultracold atomic gases. This includes aspects of superfluidity, impurities in degenerate quantum gases, few-body physics, and low-dimensional systems. He is in particular fascinated by the interplay between few- and many-body physics in strongly correlated systems.



Contact: jesper.levinsen@monash.edu

Typical systems we are interested in

• Ultracold atomic gases

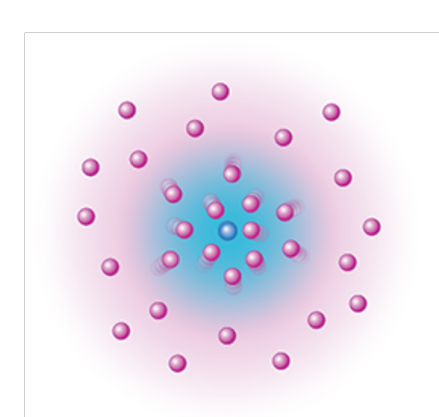

• Atomically thin semiconductors

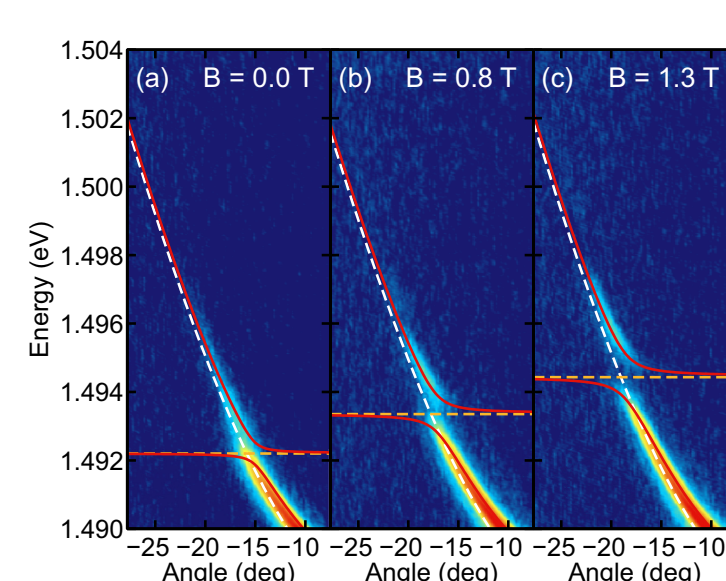

• Systems with strong light-matter coupling

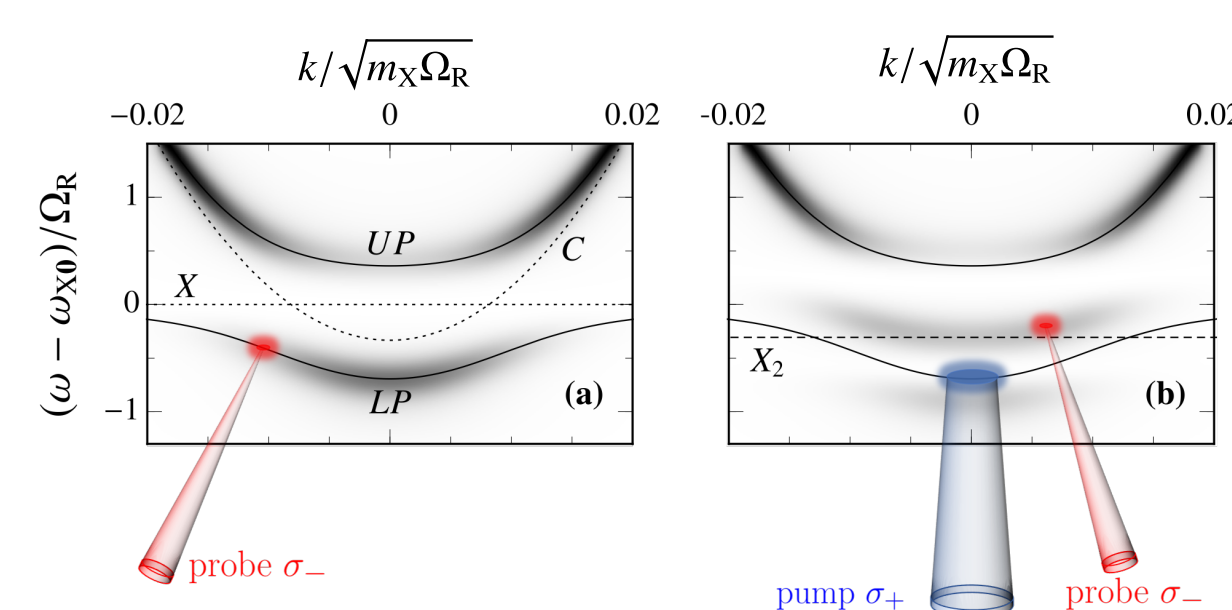

• Strongly correlated systems

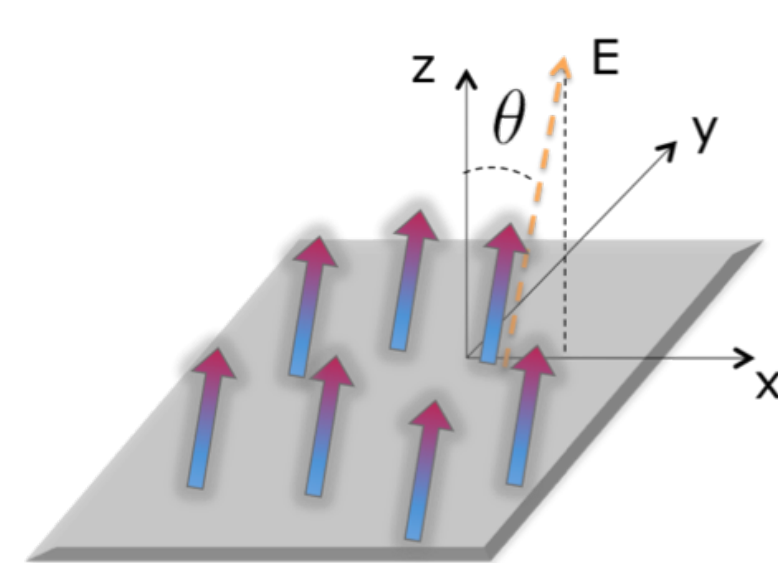

• Quantum impurity problems

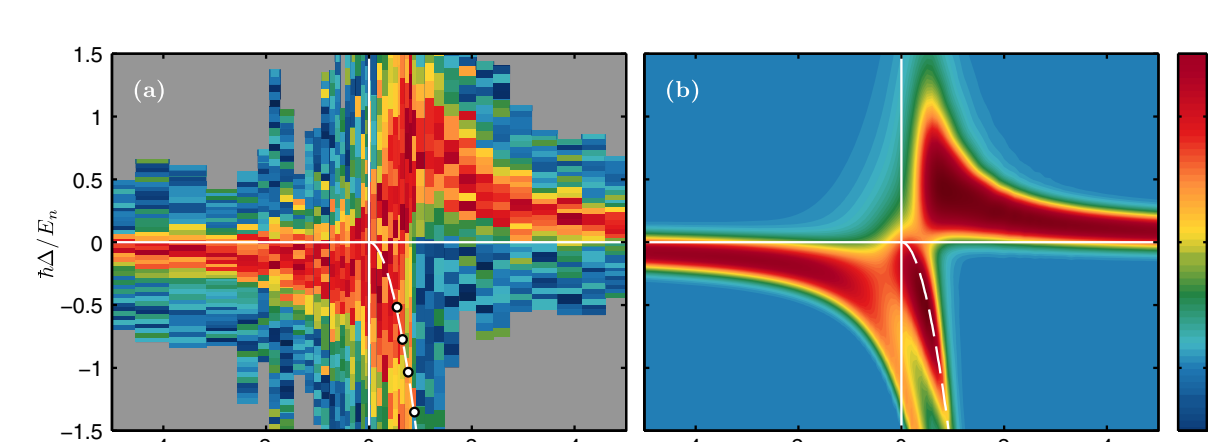

Recent honours projects

Quasiparticle lifetime of the repulsive Fermi polaron

Haydn Adlong

Here we looked at the lifetime of polaron quasiparticles in a gas of fermions, where impurity atoms become dressed by excitations of the surrounding gas. We found that a certain type of polaron (the so-called repulsive polaron) was much more short-lived than expected due to many-body dephasing. The project resulted in a paper in collaboration with experimental groups in Munich (Germany) and Florence (Italy).

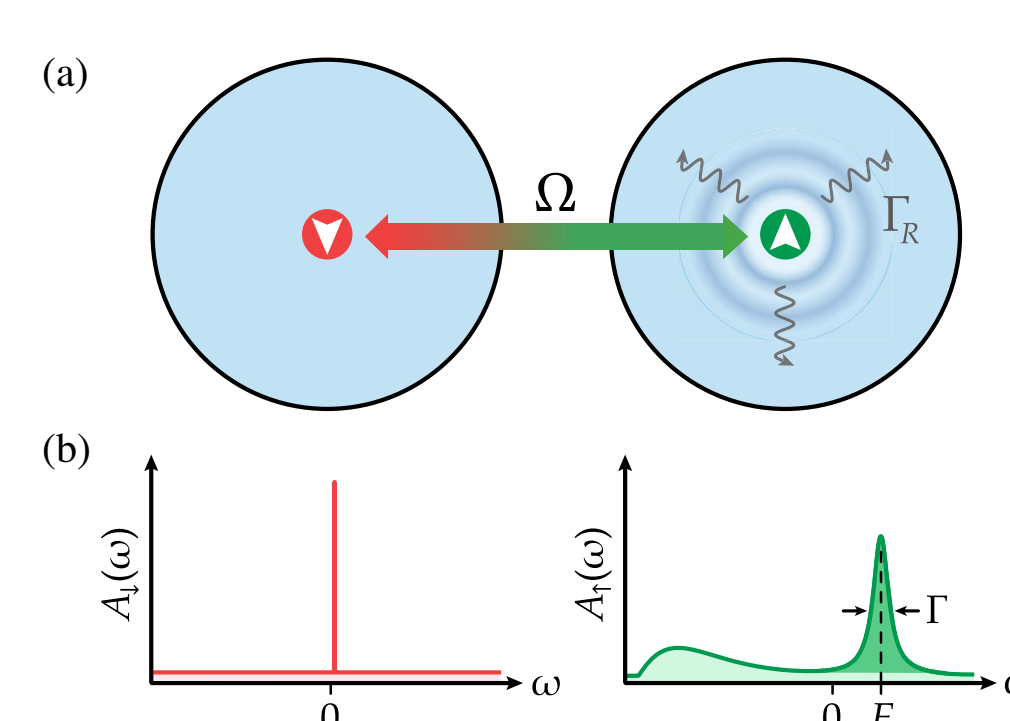

Adlong, Liu, Scazza, Zaccanti, Opong, Fölling, Parish, Levinsen, Phys. Rev. Lett. **125**, 133401 (2020)

Signatures of quantum chaos in an out-of-time-ordered tensor

Magdalini Zonnios

We investigated the case of a spin coupled to a periodically kicked rotator. We showed that this could be used as a model system for investigating quantum chaos. This project was co-supervised by quantum information theorist Kavan Modi, and resulted in a publication.

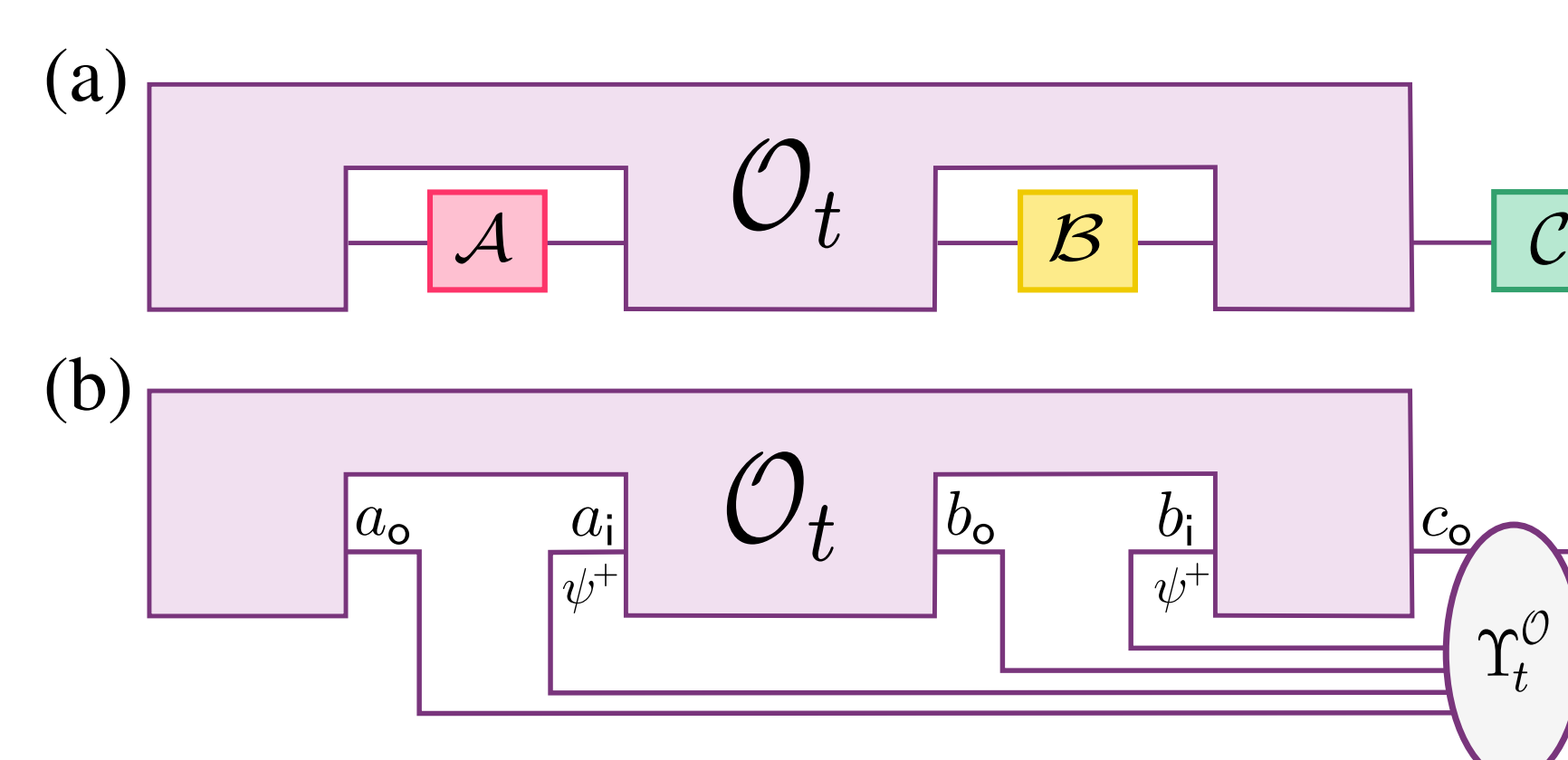

Zonnios, Levinsen, Parish, Pollock, Modi, Phys. Rev. Lett. **128**, 150601 (2022)

Fate of the Bose polaron at finite temperature

Bernard Field

This project investigated the behaviour of an impurity atom immersed in a gas of bosons. We found that the impurity could split into multiple quasiparticles when the bosons condensed at low temperatures, due to the interplay between quantum and classical physics.

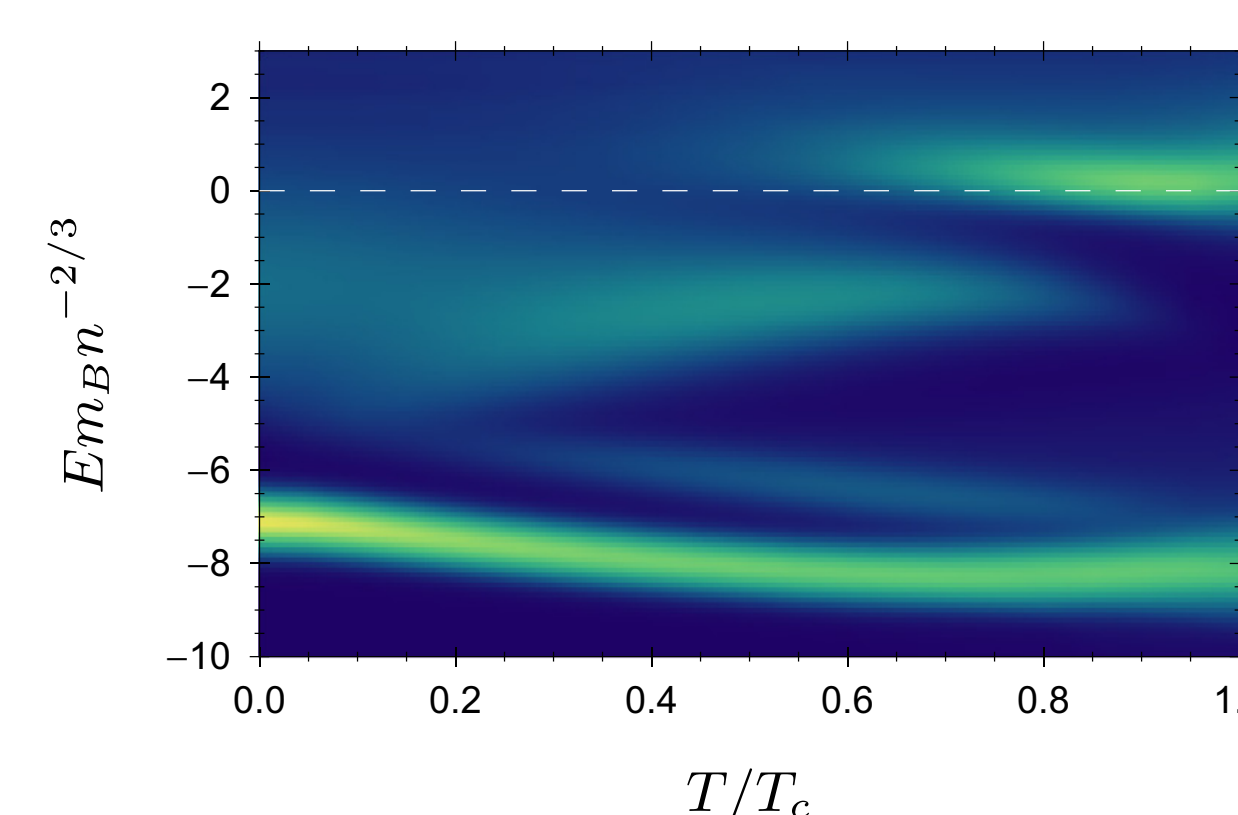

Field, Levinsen, Parish, Phys. Rev. A **101**, 013623 (2020)