

Squirrel*

* to move in an inquisitive and restless manner

Reconciliation is more than a week in the calendar

Aboriginal Flag designed by Harold Thomas, Luritja People (1971)



it's an ongoing commitment

'The theme for National Reconciliation Week 2020 was "In this together". Are we really? If we look at things as they are, we would surely have to doubt this. Instead, we should ask, "What would it take for us to be truly in it together?". It would take truth-telling. It would take respectful and honourable partnerships'

— **Jacinta Elston**
Pro Vice-Chancellor (Indigenous)
& Head, William Cooper Institute

Tap on the text to read Jacinta's entire article in Lens

Tap on any of the links to connect and pledge support

[Victorian Aboriginal Legal Service](#)

[Justice for David Dungay Junior](#)

[Sisters Inside Bail](#)

[AIME mentoring](#)

[Black Rainbow](#)

[Bush Mob Aboriginal Incorporation](#)

[Grandmothers against removals](#)

[First Nations Resource Directory](#)

[Victorian Women's Trust](#)

Squirrel*

* to move in an inquisitive and restless manner

FROM THE HOD



Gene Bawden
 Head of Department, Design

2020 has been a year unlike any other. The devastation of the Australian bushfires that made news headlines around the world was swiftly followed by the impact of a deadly global pandemic. And now the protests occurring in the United States has shifted the spotlight from a viral anomaly to a scourge that has impacted the entire world—**including Australia**—for centuries; the injustice of systems that permit prejudice and inequality. But, the protests are also a sign that a movement is afoot, the ethos of which echoes the Civil Rights Movement of the 1950s and ‘60s. While the awful truth of racial injustice is being laid bare, the protests are making clear that there is a generation ahead seeking to activate positive change. Amid the chaos of our times there is also hope and optimism. As the last ‘Squirrel’ for Semester 1, I leave you with one ambition: to be the designer the world needs—the designer who creates, enables and amplifies positive change.

Right:
 ‘It’s gonna be ok’
 Mel Coombes,
 Teaching Associate

‘It was Sunday and the cold and isolation were starting to take a toll. I’d baked the sourdough, I’d done the brisk walk, I’d zoomed the buddies, I’d set the fire - nothing was hitting the mark. As I fretted about the house unable to focus on anything in particular and searching vaguely for something I now suspect to have been a well-misplaced pair of rose coloured glasses, I glanced out of the window and ‘bang’ there it was! Immediately transported out of my head I was 5 years old again and flapping about like it was the first rainbow I’d ever seen. “It’s gonna be ok” I thought - look up, look out, and focus on the beauty and diversity that are there every day for the noticing.’



WOTTA WATCH

The Blood of a Poet (Le sang d'un poète) is Jean Cocteau's bizarre, high-camp surrealist creation from 1930... what's not to love? While the scene transitions are written in French, the story can be followed through Cocteau's brilliance as an image-making: 'Few drug-induced visions... can match the playful ingenuity of this freewheeling assault on the senses, which eschews conventional narrative in favour of one mesmerizingly bizarre image after another. "Oneiric" is a word that often comes up in reviews and essays, but 'The Blood of a Poet' isn't so much dreamlike as it is what a person might experience if kept continuously awake for days on end.' — Mike D'Angelo TAP THE IMAGE BELOW TO WATCH ON VIMEO

» Watch the trailer



Above: Into the flame (<https://vimeo.com/349111588>)

NED'S SHORT PICK

Into The Flame — A Hue&Cry Film

"Life begins to unravel for Floyd — an overworked, unfulfilled businessman — in his wife's sudden absence. So many questions. So many seemingly strange answers leading him forward. Moths are appearing all around him and no matter what he tries, he can't halt the visions. In a panic, he flees, running wildly for days. Exhausted, there seems to be no escape for Floyd ... but in the end there may be no end at all." —Vimeo

Tap the image to watch on Vimeo/ Tap here to see more about the film.

LISTEN UP

Spaced Apart is an online design, art, photography and sound symposium that brings us closer together while we are spaced apart. Free for all and live-streamed on the Spaced Apart website.

Spaced Apart speaks to the importance of maintaining social connection and solidarity in the face of crises, and the importance of continuing culture and supporting the creative arts. The symposium will bring together a series of live presentations from 18 speakers, providing audiences with cultural and social stimulation in a time of global lockdown. In reflecting on their work, presenters are invited to contemplate themes of solitude and togetherness, loneliness and sociability, and how these states of being might inform the process of creation. The online platform aims to provide an accessible, interactive space for sharing ideas; a space to realise new modes of digital and remote creative collaboration and exchange – one that will have ongoing relevance beyond the current pandemic.

Spaced Apart is an initiative by Melbourne creative practice U-P. Uriah Gray (from U-P) teaches Digital Publishing in Communication Design.

[Tap here to connect to U-P.](#) Tap the image to connect to the Spaced Apart website and live-stream program.



Yuri Suzuki
04.06.2020 8:00-9:00PM (AEST)
Curated by Molonglo

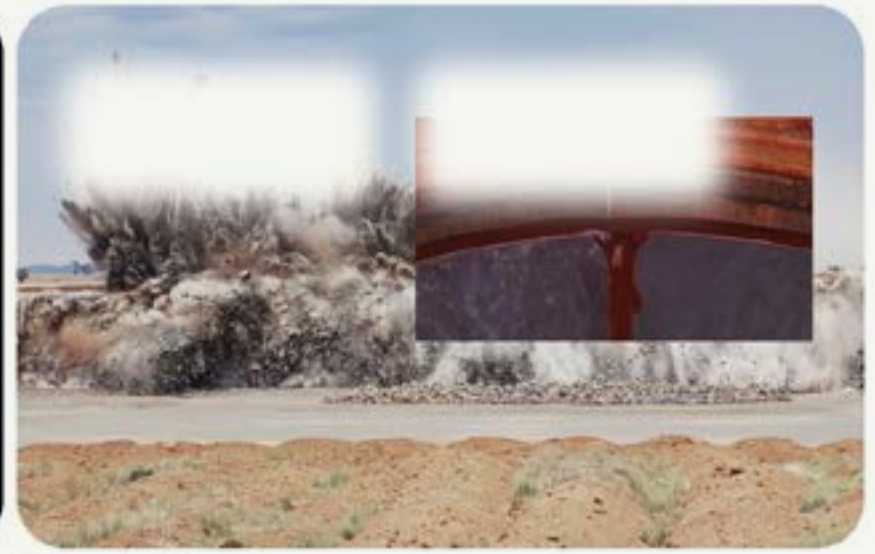

Georgia Nowak
07.06.2020 8:00-9:00PM (AEST)
Curated by Denise Neri (Aesop)



Lucas Blalock
09.06.2020 10:00-11:00AM (AEST)
Curated by PHOTO 2021



Tamar Shafir
11.06.2020 10:00-11:00AM (AEST)
Curated by Molonglo



James Goggin
14.06.2020 10:00-11:00AM (AEST)
Curated by U-P



Roseanne Bartley
16.06.2020 10:00-11:00AM (AEST)
Curated by RMIT Design Hub Gallery

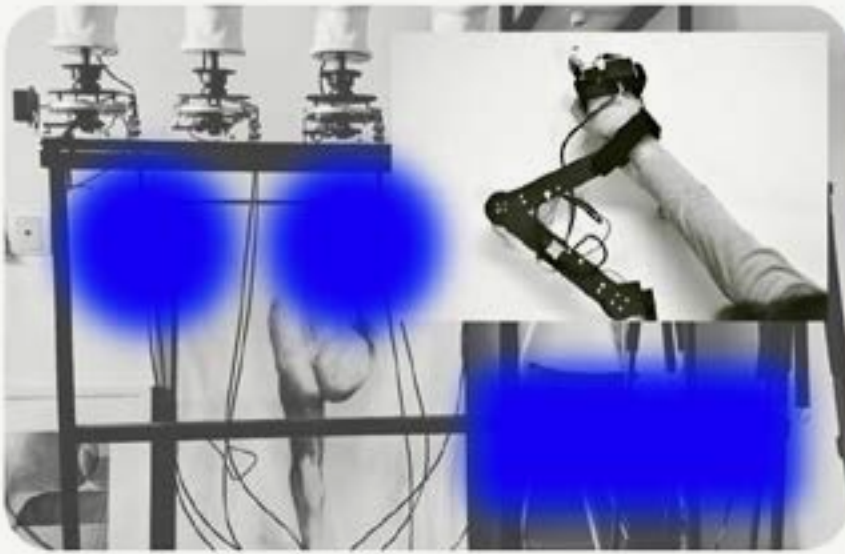

Saurabh Datta
18.06.2020 8:00-9:00PM (AEST)
Curated by Keinton Butler (Powerhouse Museum)



Pretziada
21.06.2020 8:00-9:00PM (AEST)
Curated by Molonglo



Tin & Ed
23.06.2020 8:00-9:00PM (AEST)
Curated by RMIT Design Hub Gallery



Brook Andrew
23.06.2020 10:00-11:00AM (AEST)
Curated by Denise Neri (Aesop)

FOLLOW

Be inspired and seek out those that are collating and creating the best work for us to observe and critique from around the world.



Communication Arts
Magazine
USA

» CA website



Domus
Magazine
Italy

» Domus website



Idea
Magazine
Japan

» Idea website

NICE WORK

Master of Design & Zoos Victoria Internship.

Five students from the Master of Design cohort have been working with Zoos Victoria to create an immersive and engaging experience for primary school students, focusing on five local Australian species. The design outcome features unique craft-based learning and augmented reality experience that Zoos Victoria will be rolling out state-wide later this year.

The Master of Design students have designed species-specific environments using recycled tissue boxes and downloadable templates, which primary school students will use to recreate a mini diorama in their classrooms. With the custom-designed QR code pasted within the tissue box, the species come to life with the aid of augmented reality. Helping create an understanding of the species local environment and the unique characteristics of the five animals, the Tassie Devil, Southern Bent Winged Bat, Brushed Tailed Rock Wallaby, Helmeted Honey Eater and Eastern Barred Bandicoot. The design outcome will be a featured education resource for the Zoo and part of their Love Your Locals campaign.

Congratulations to students Xin Chen, Dongyu Liu, Riri Haruka, Jiongxin Wang and Ankit Khokhra, and staff Jeff Janet, Nao Hayakawa and Dr Debbie Symons for developing this project to market.

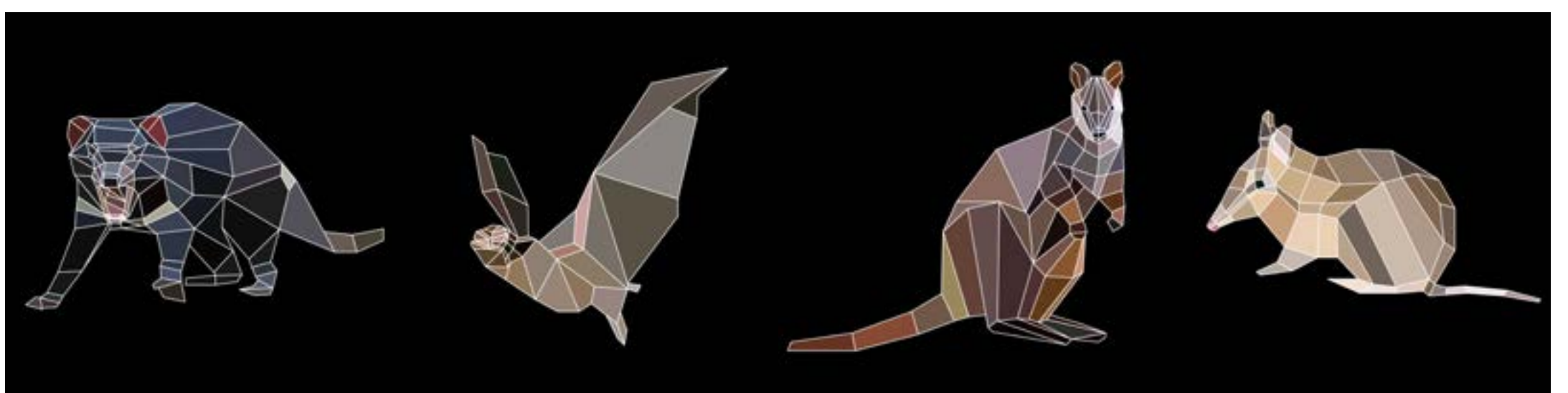
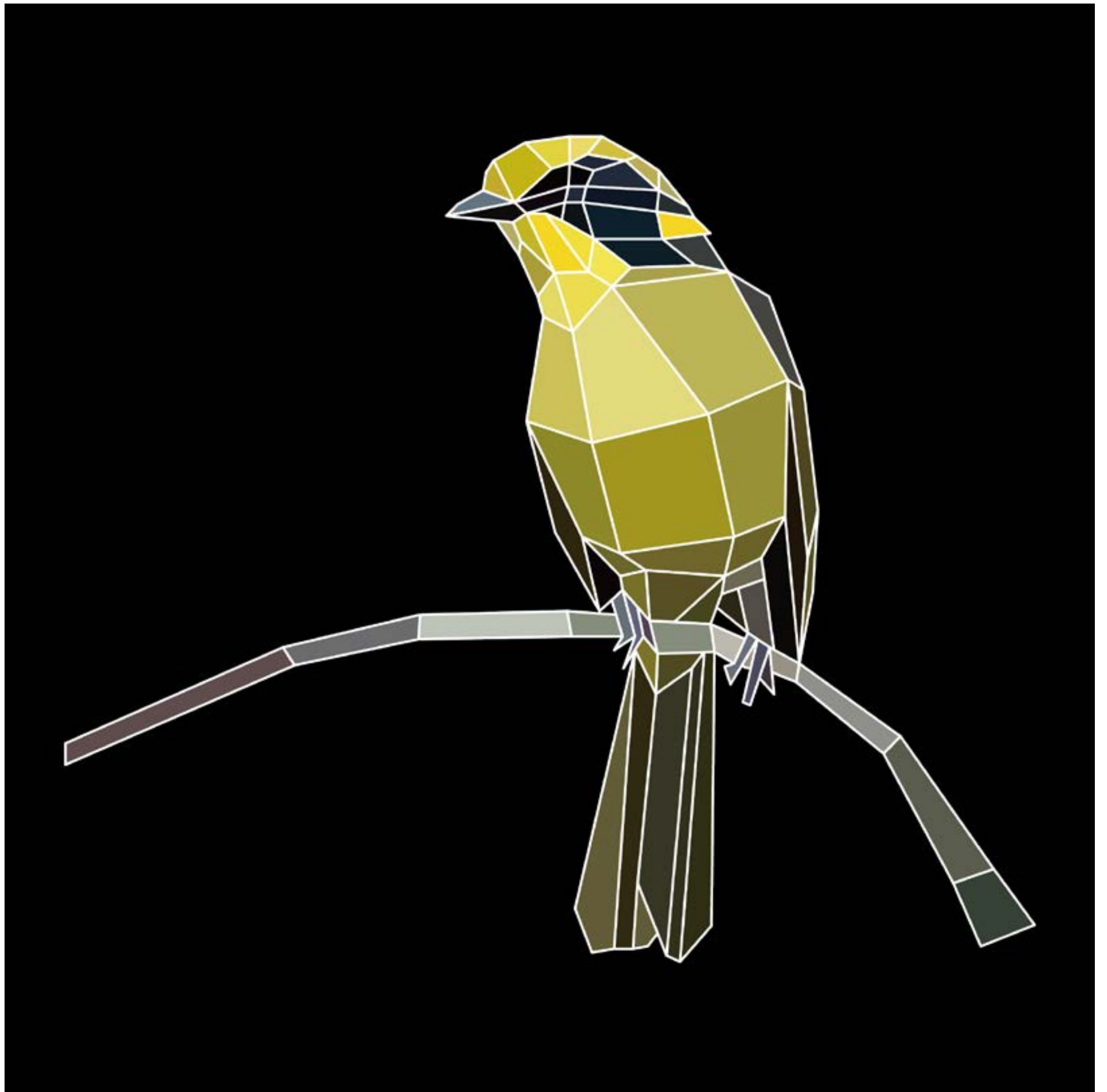

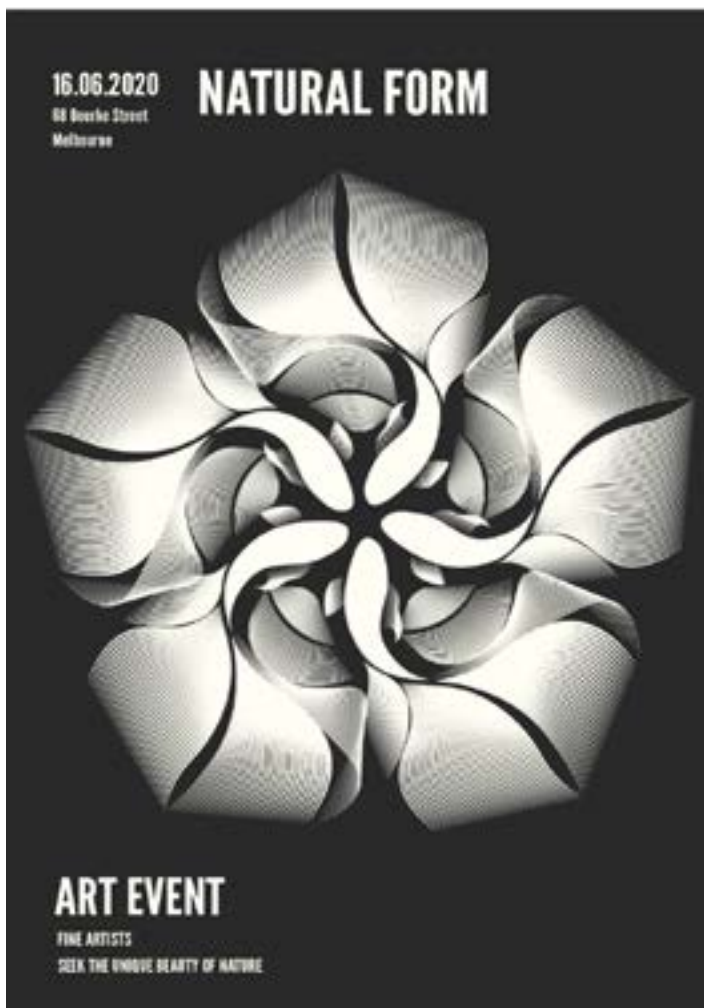

Communication Design
Studio 3 (CDS2001)
Lecturer: Ned Culic
Project: Event Promotion

Clockwise from top left:
 Natural Form, Cao Yuchan
 Melbourne Japanese Festival, Ren Lu
 Japanese Children Day, Liu Lin
 Golden Plains, Jack Clausen
 Witchfest, Linh Tran

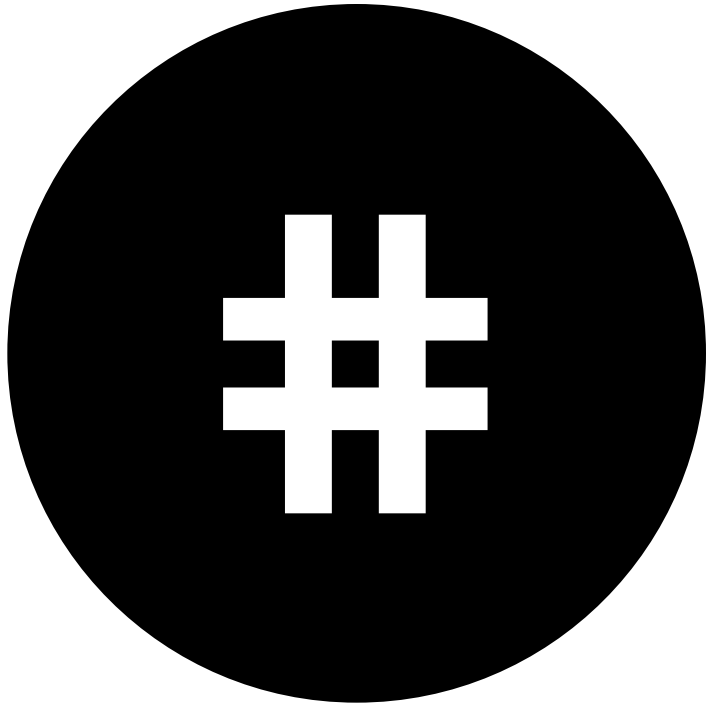

#monashada

Follow ALL your peers;
follow the hashtags

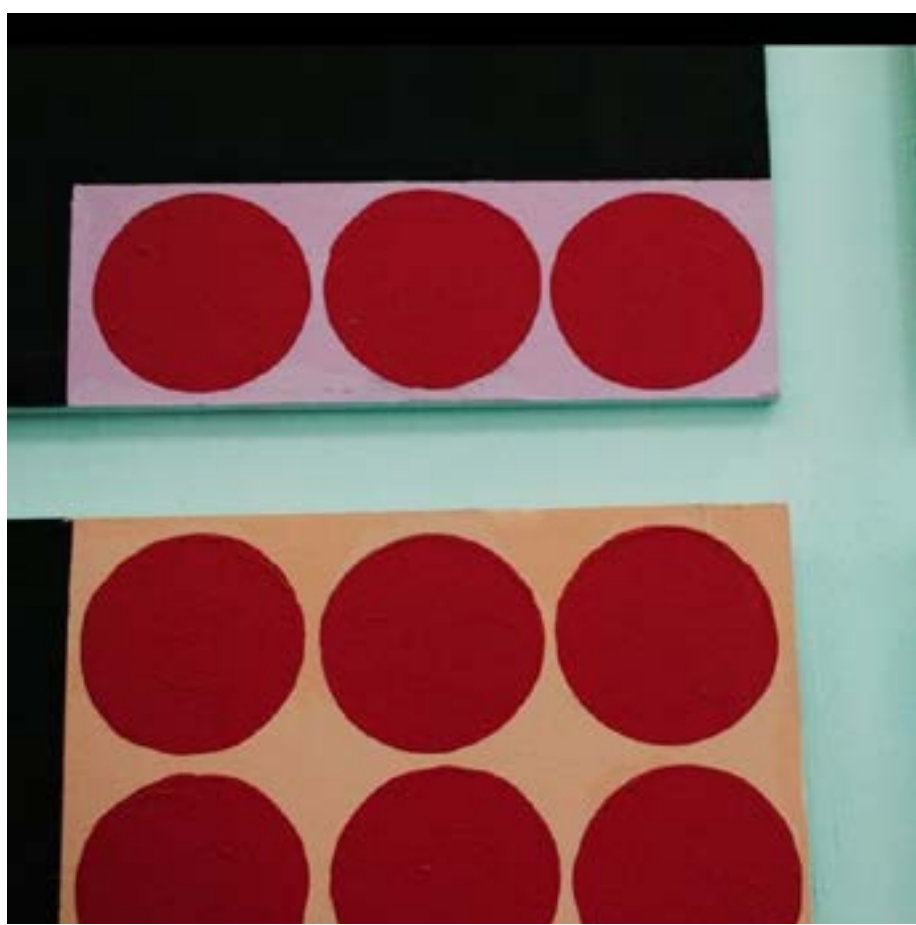



A significant number of students in Communication Design ‘elect’ to study the ‘Motion Design’ stream within the Communication Design studio sequence (CDS2001—3002). This week, we celebrate **Ann Li Khaw’s** advertising animation promoting the Monash Drawing Club. Ann has communicated through simple facial expressions, eye movements and actions such a wealth of emotion and connectedness to her audience... all in less than 20 seconds! There are three animations in total, so take a look at all of them on the Squirrel YouTube channel.

Just tap the TV to connect to the animation on YouTube.

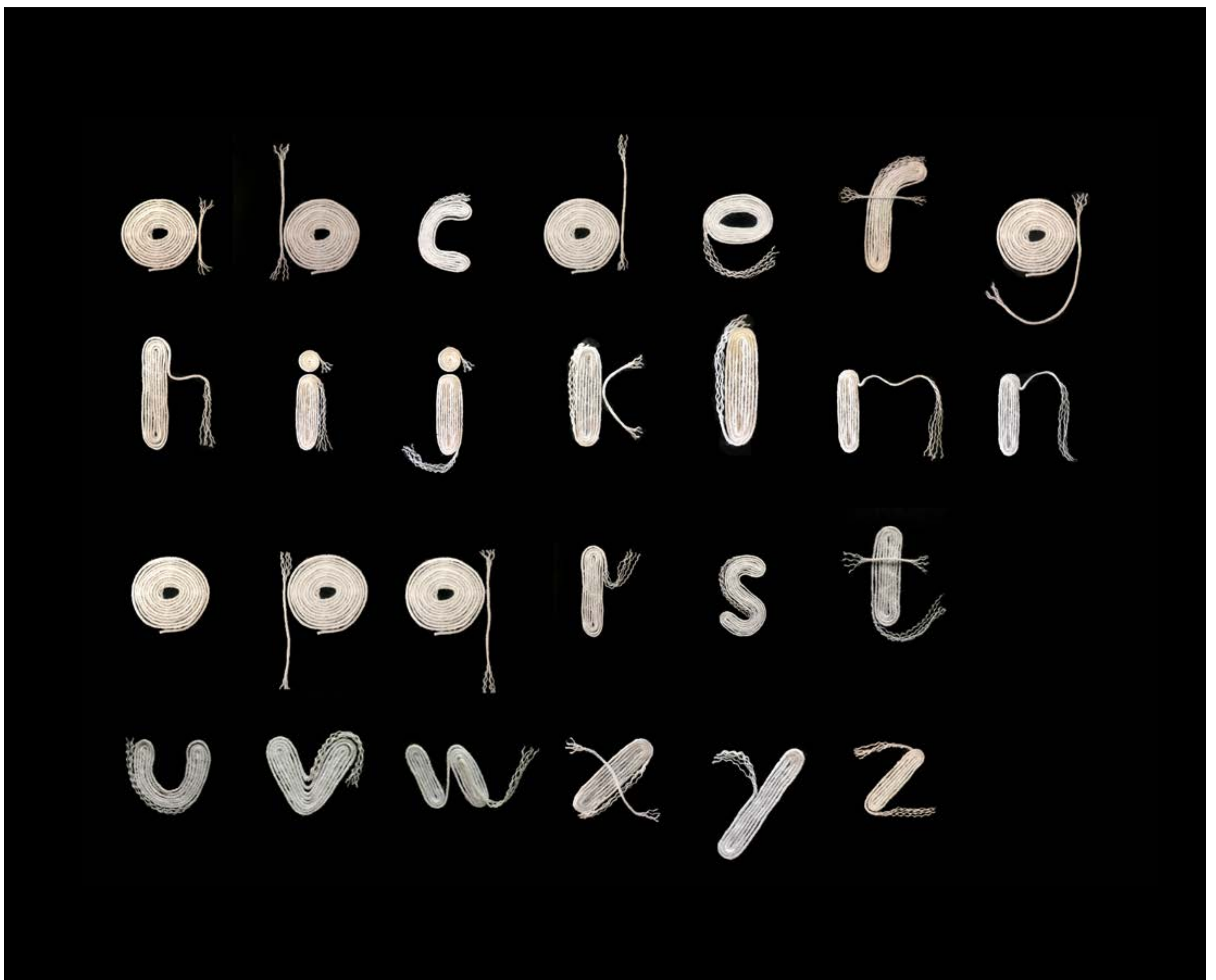

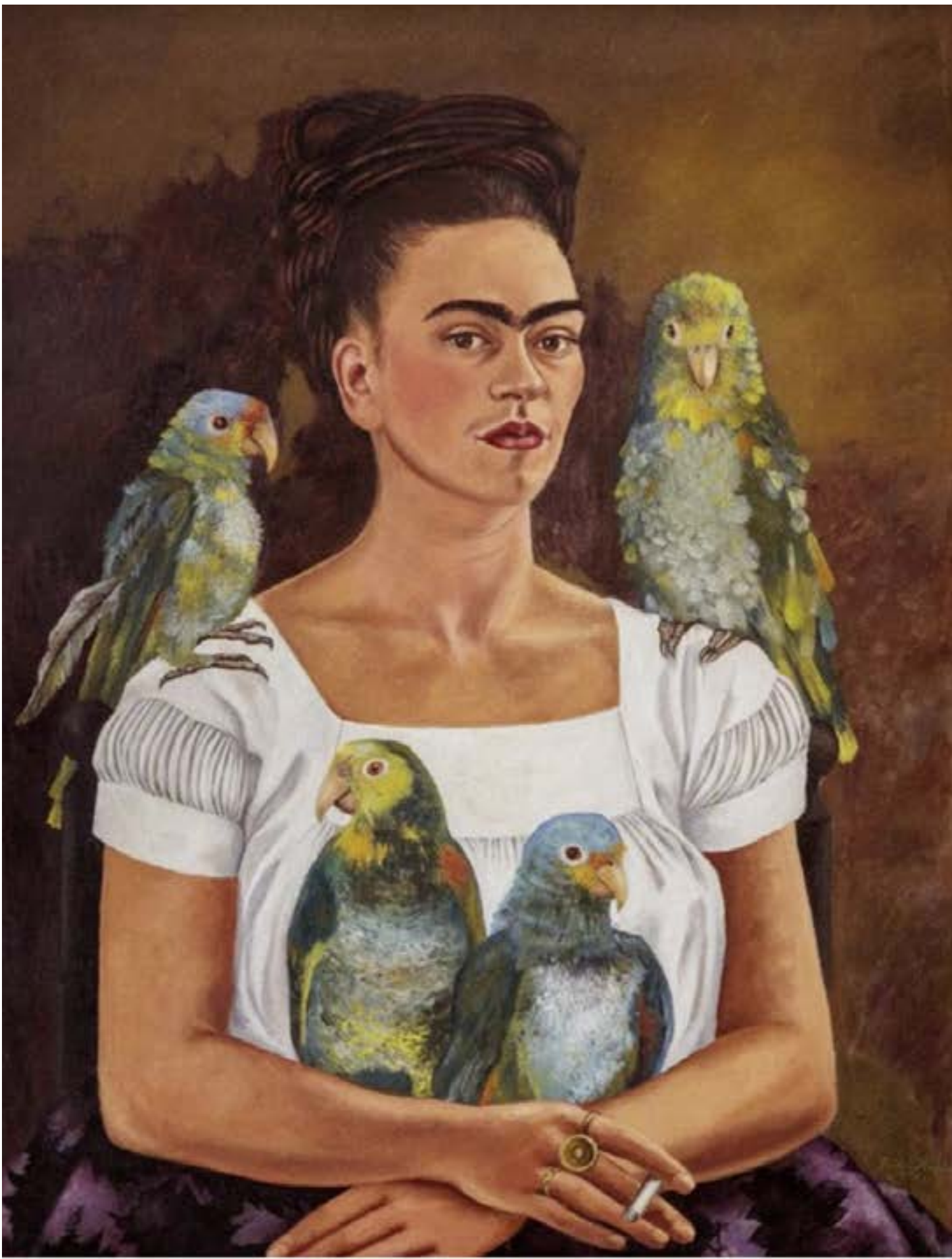

Me and My Parrots

Artist: Frida Kahlo
 Date: 1941
 Period: Naive art
 Dimensions: 82 cm x 63 cm
 Medium: Oil paint



Me and My Windex

Artist: Alexandra Patrono-Smith
 Date: 2020
 Period: Modern
 Dimensions: 82 cm x 63 cm
 Materials: Detergent bottles, towels, brassiere, eyeliner

ELECTIVE
**SPOT
 LIGHT**

**Design for culture
 and heritage (DGN5203)**
 Lecturer: Vince Dziekan
 Project: #museumathome



Top: Frida Kahlo/ Alexandra Patrono-Smith
Above: Paul Klee/ Wangya Tan
Above right: René Magritte/ Shiwei Dong
Right: Frans Pourbus the Younger/ Jianliang Fu

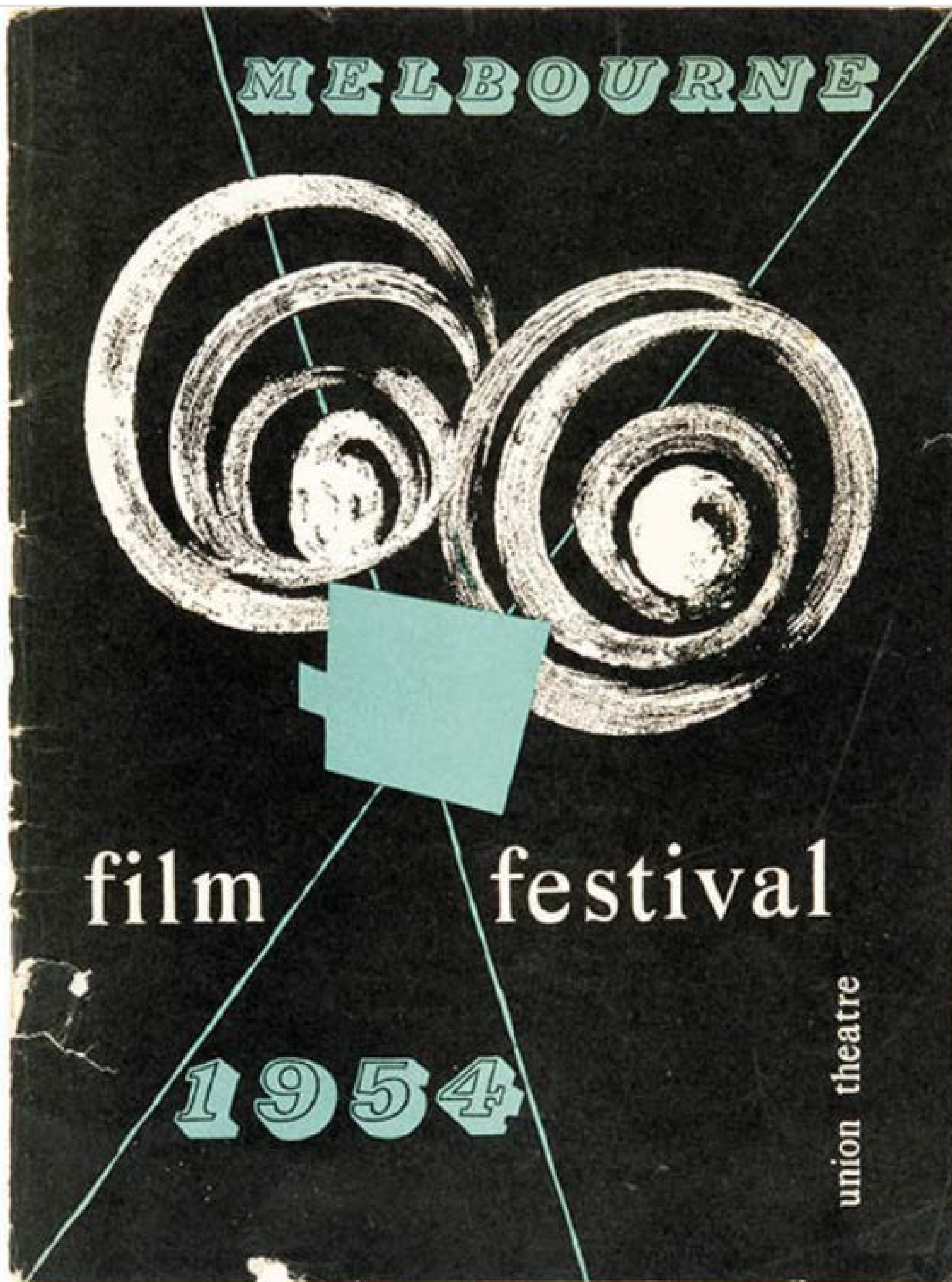

Introducing MIFF 68½ — a Digital Film Festival for 2020

Discovering new possibilities in the face of dramatic disruptions in the global film industry, The Melbourne International Film Festival has announced a new online showcase for 2020 to deliver a program of new-release films from around the world. Following the cancellation of MIFF 2020, they have been working on MIFF 68½, a reimagined celebration of cinema online, featuring a suite of films and special events. With the adoption of streaming technology, their iconic film festival will return this winter to deliver new worlds of cinematic escape. **Tap the image to find out more**

Above 1954 Melbourne International Film Festival program by [Max Robinson](#) (1934-2018)

Image: RMIT Design Archives

Studio of the week

Decade

www.decade.studio

Monash Graduate **Sam Moffat** is Director of Decade, 'a brand development and design studio from Hobart, Tasmania, (who) create brands that engage, inspire and endure.' Sam has worked with a broad spectrum of clients at all scales – from large global enterprises (Bacardi, Airbnb, British Rail, Oracle, Sage, BASF, Bentley, Tate Modern) down to innovative start-ups. After almost ten years in London he's recently moved (back) to Hobart. **Tap the panel** to connect with Sam through Instagram





ArtActivistBarbie (by Sarah Williamson in ‘The Conversation’)

“Say hello to ArtActivistBarbie (AAB), whose modus operandi is small signs, big questions and a fabulous wardrobe. With her inviting call to arms, “Refuse to be the muse!” this fierce new incarnation of Barbie is helping to challenge art galleries and museums worldwide about their woeful lack of women and other minorities in their collections, and reluctance to consider the female gaze... Thousands follow her on Twitter, enjoying her playful disruption and creative interventions which ask questions and raise issues about gender”. **Tap the image to see and read more.**



Launched in 2019, the Emerging Technologies Research Lab sits across the faculties of Information Technology and of Art Design & Architecture at Monash University.

It investigates an emerging technological environment where automation, artificial intelligence, data and the questions of ethics, responsibility and user experience and engagement that they bring with them are increasingly central. The Lab’s core themes include energy futures, future mobilities, public space, e-waste, and design for wellbeing.

Recently the Lab launched its online publication, ‘Future Matters’. “Future Matters” is a place... to speak critically about what’s happening in the world, show the vitality of research from the Emerging Technologies Research Lab, and set the tone for how society can reimagine their futures’.

Tap the cover image, right, to connect to issue one. And to prove this Squirrel reads, [this link](#) really stood out. Enjoy:)

1 The Changing Role of Home During Crisis

Sarah Pink
Shanti Sumartojo
Yolande Strengers
Melisa Duque
Kari Dahlgren

FUTURE MATTERS



Sarah Annett
Illustration for narrative
Surface design—Seaweed
Lecturers:
Ned Culic
Tracie Grimwood

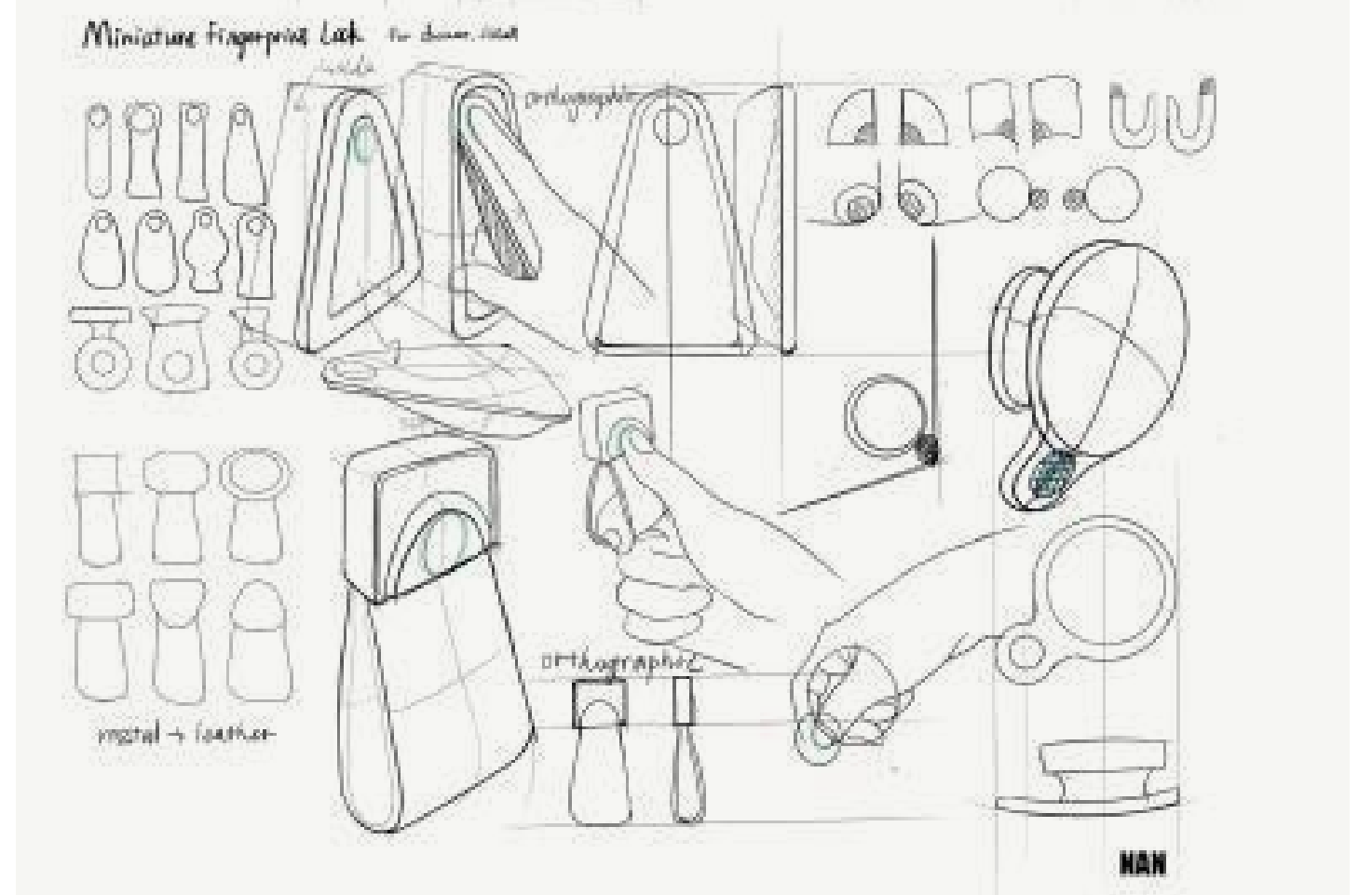
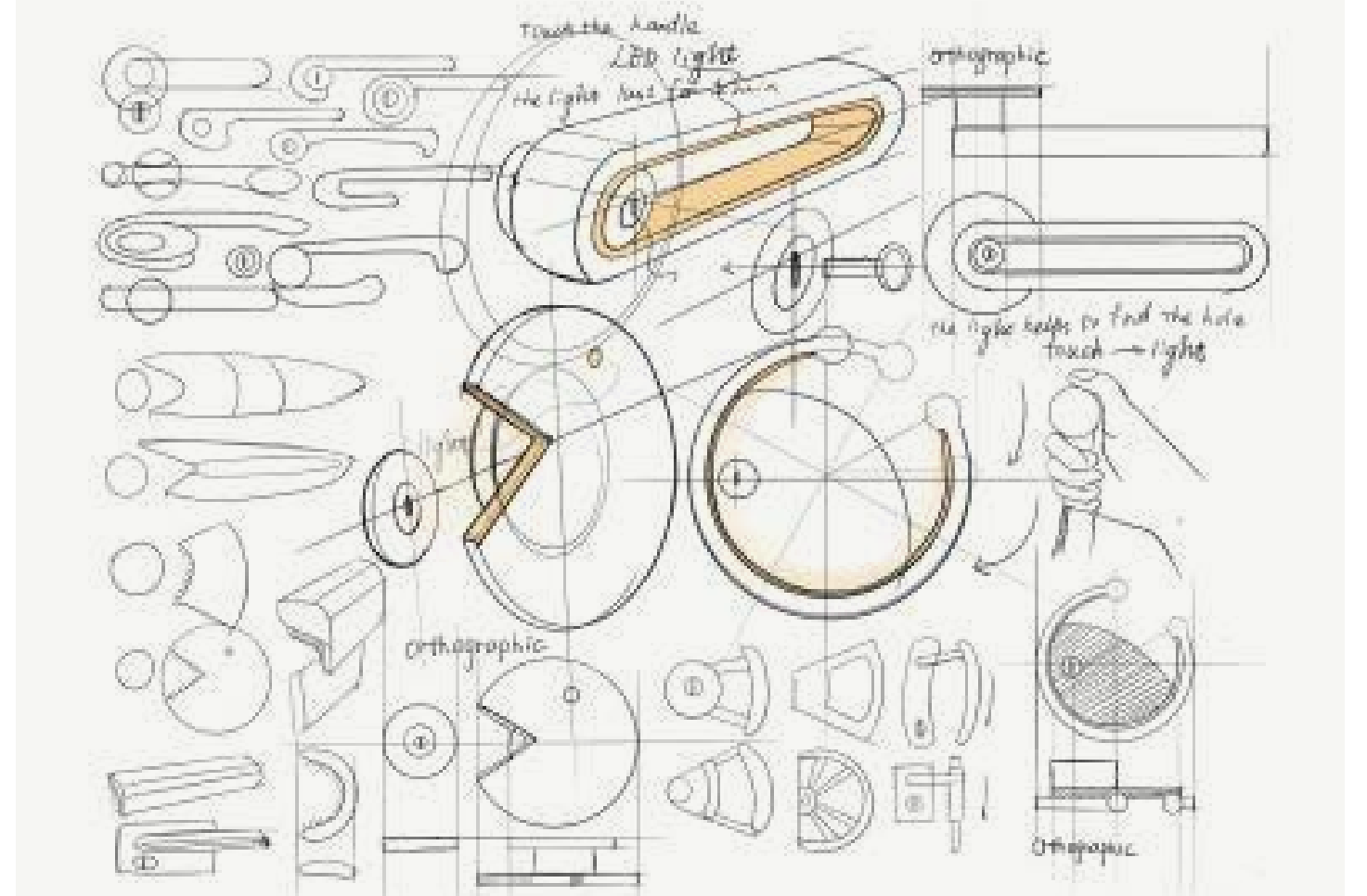
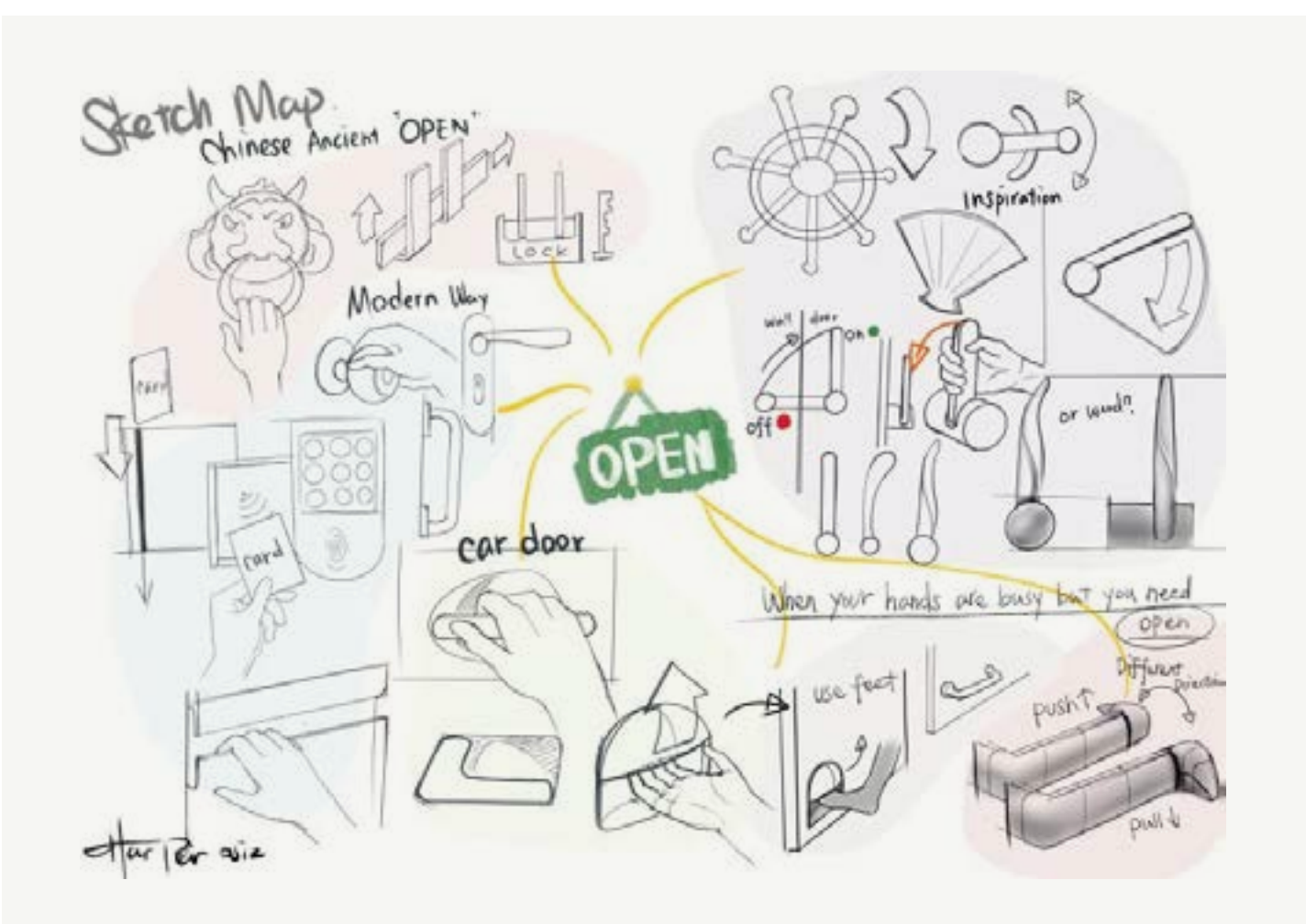
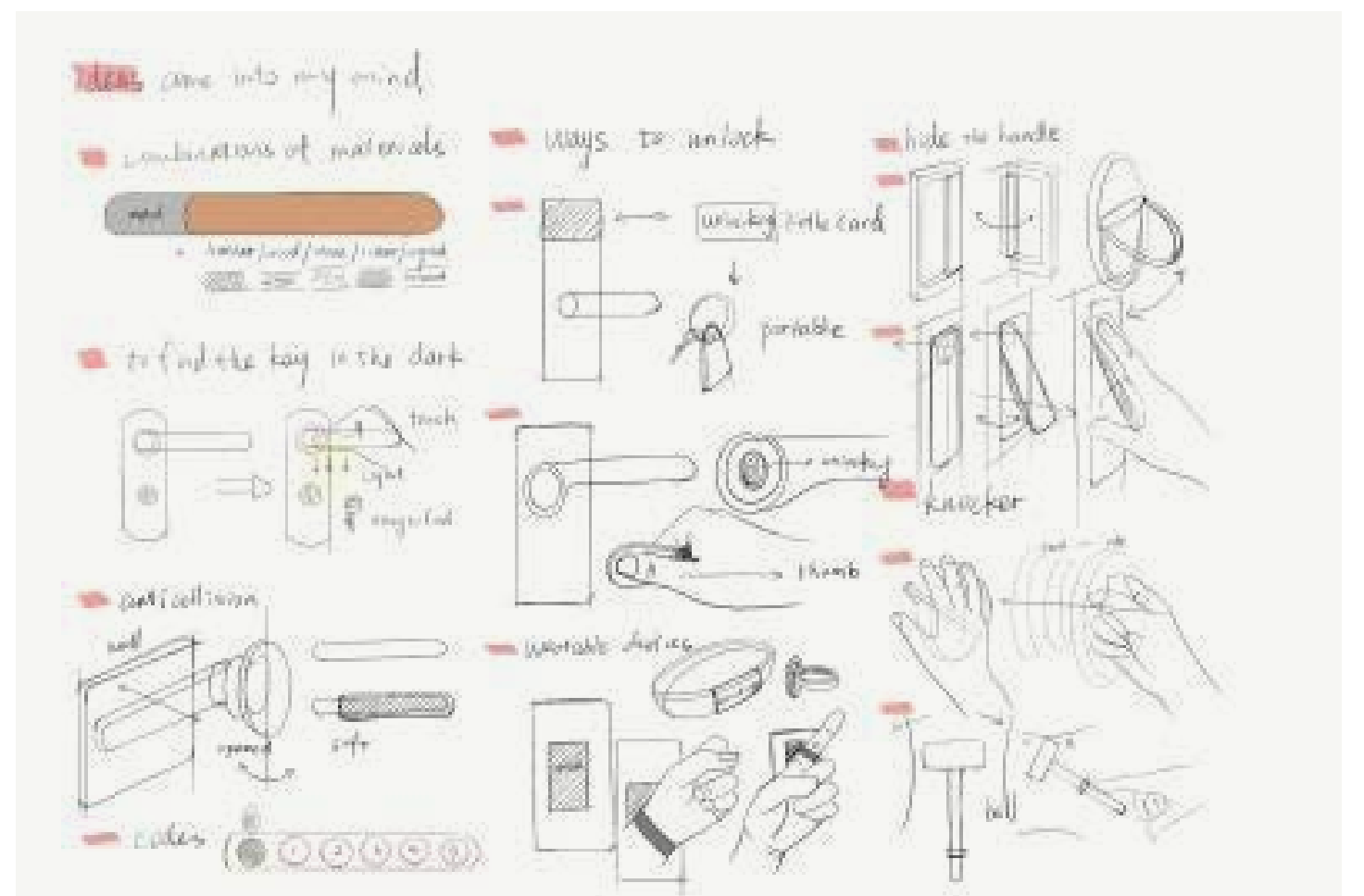
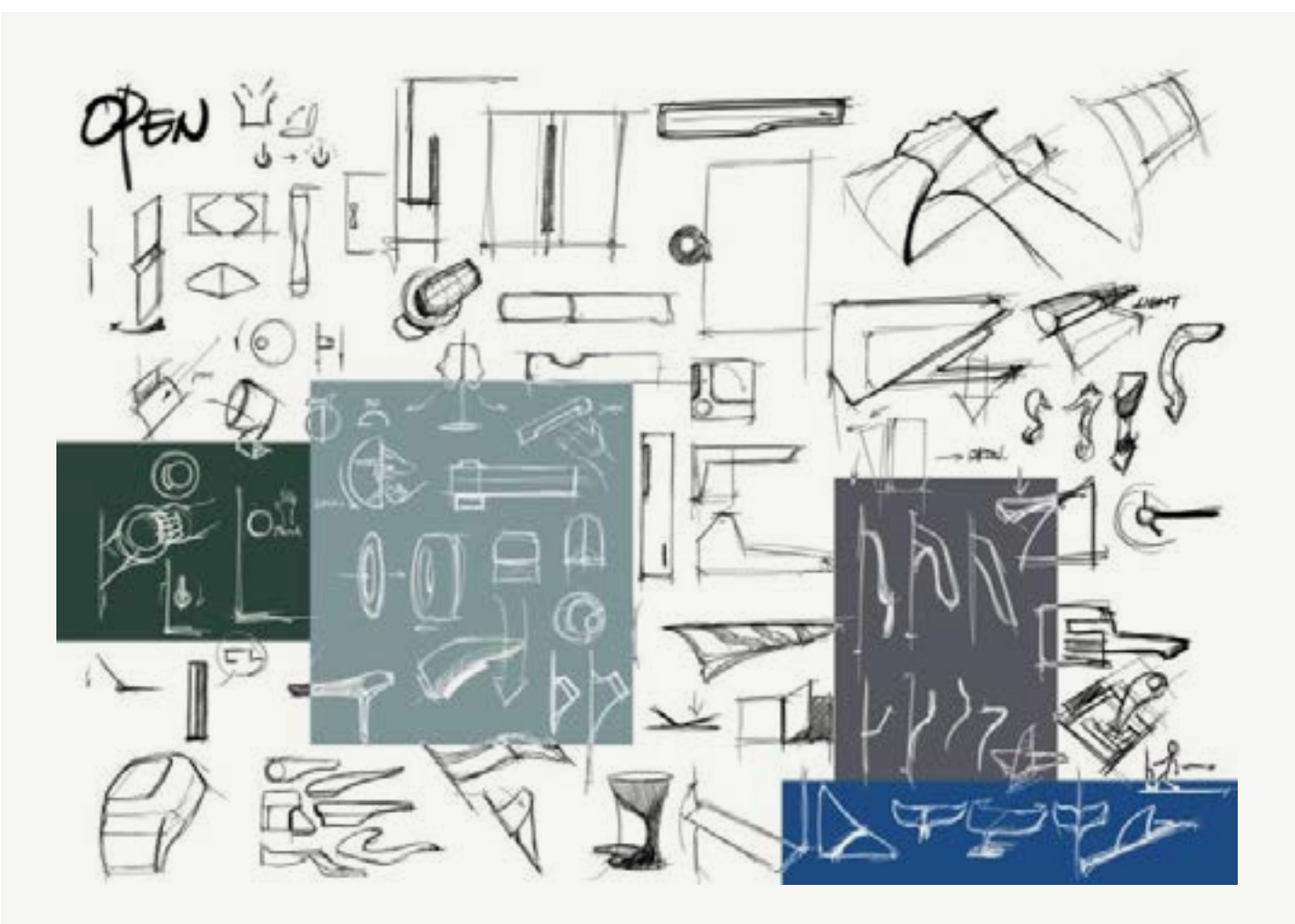
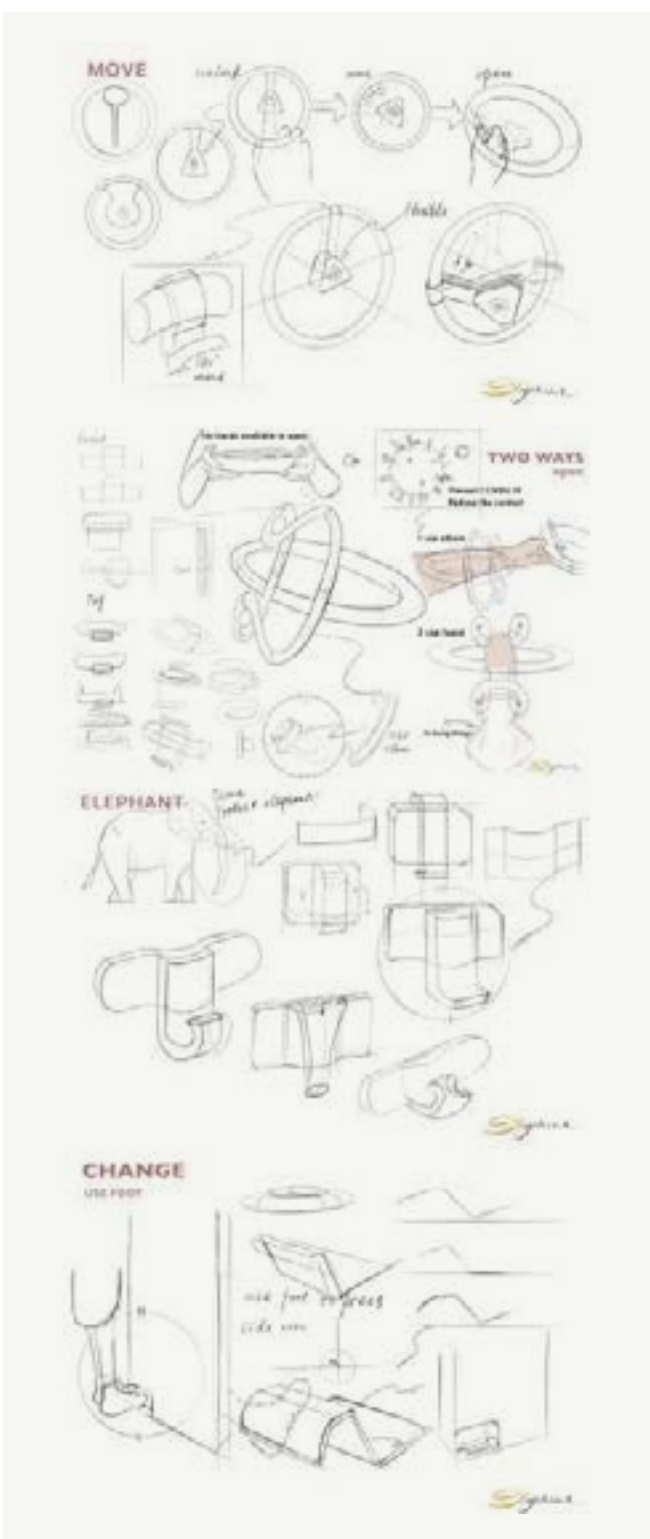

The 'Open' Project

Our Suzhou cohort once again demonstrating the value of drawing and visualising ideas... lots of ideas! Lecturers Phil and Bernie have praised the students for their dedication and productivity (and the unexpected upside of isolation... the time to be productive!)



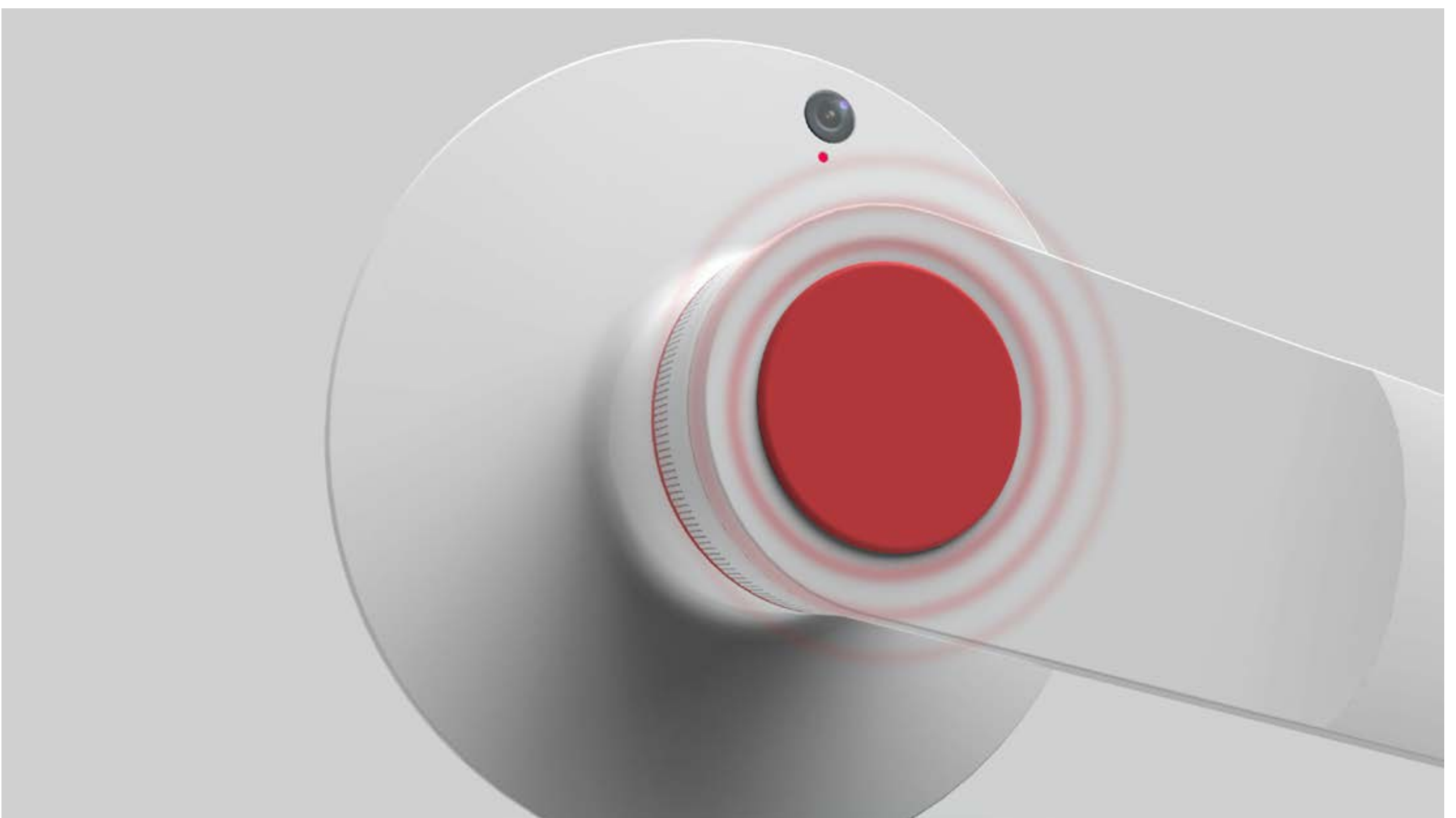
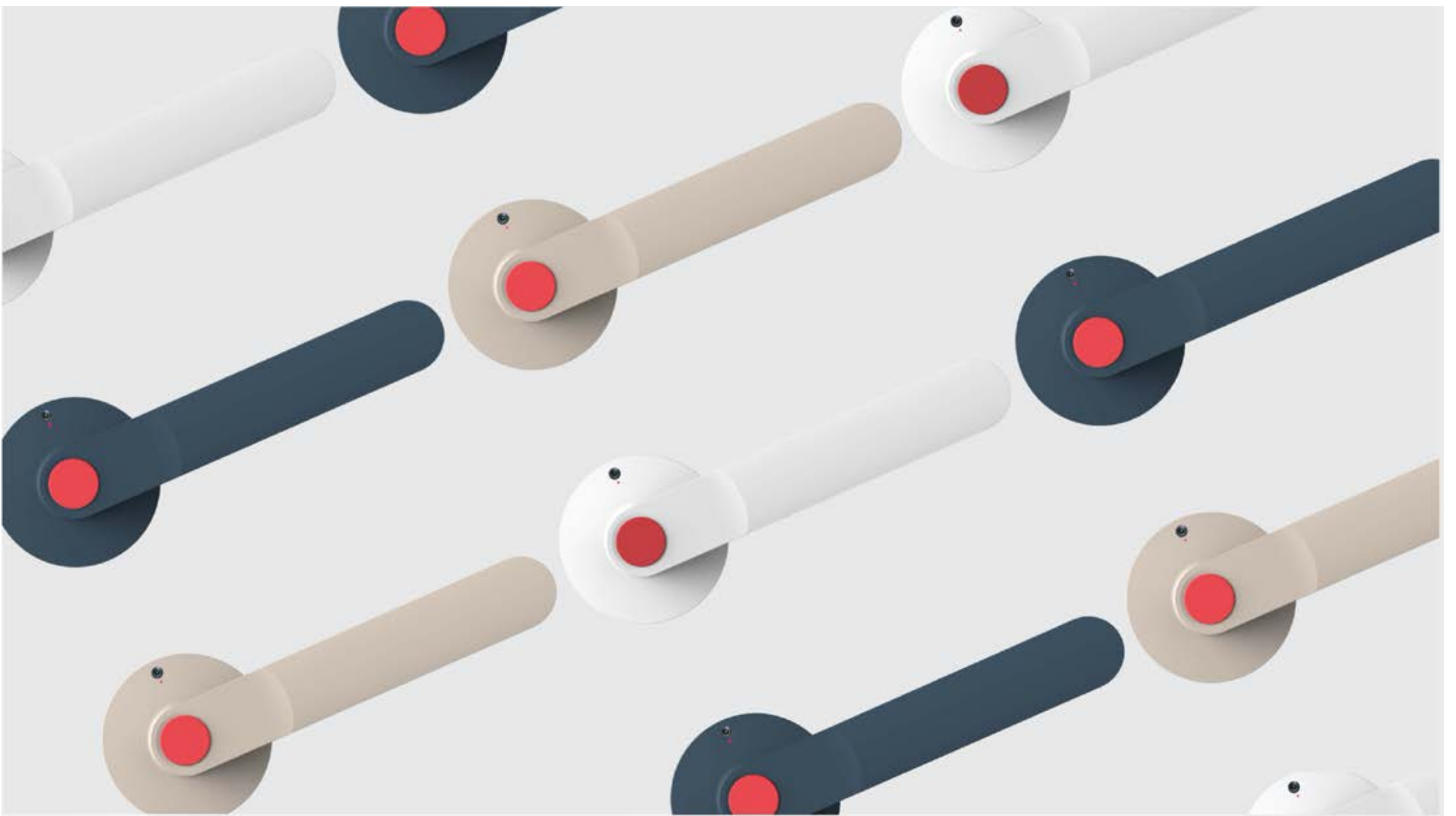

PROJECT
**SPOT
LIGHT**

Suzhou student Cecilia has fully developed her 'Open' project. This smart security door system — 'Aura'— allows the resident to view video footage on their smart phone, program personal lock out settings, and unlock their door remotely. In the event of a break-in Aura would immediately notify the emergency services.

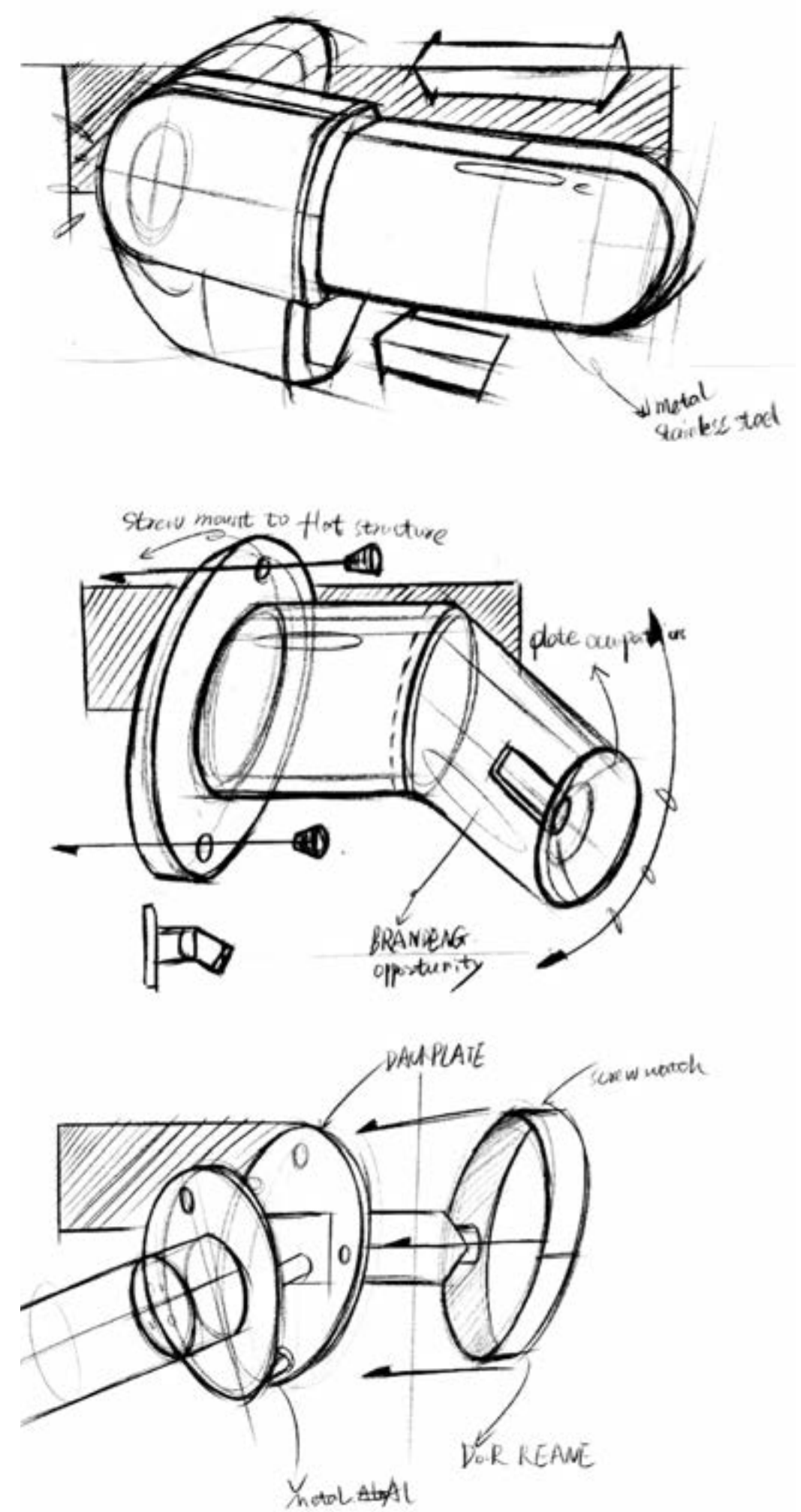

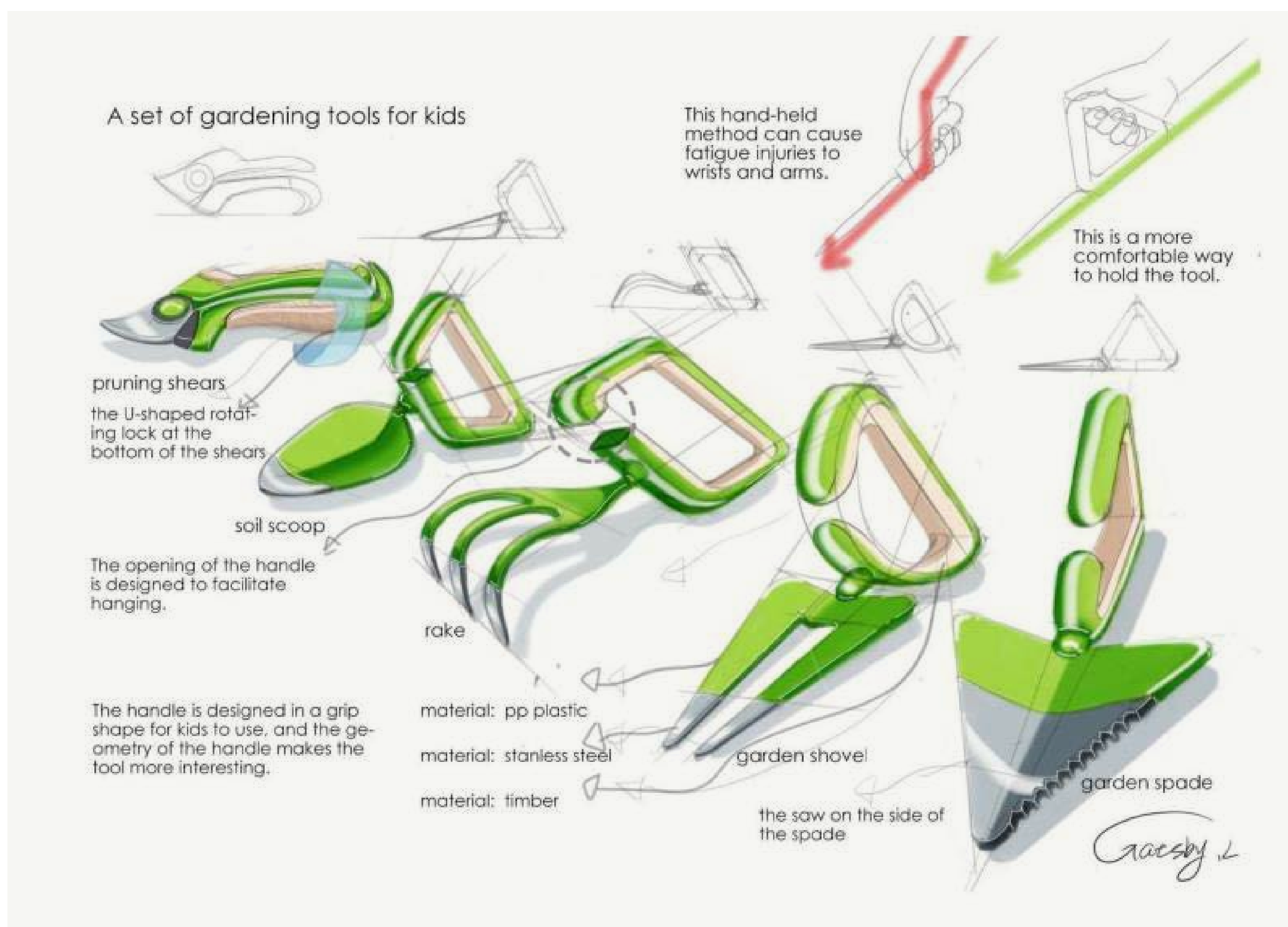

HAPPY 118th BIRTHDAY!
SUZHOU

PROJECT
SPOT LIGHT

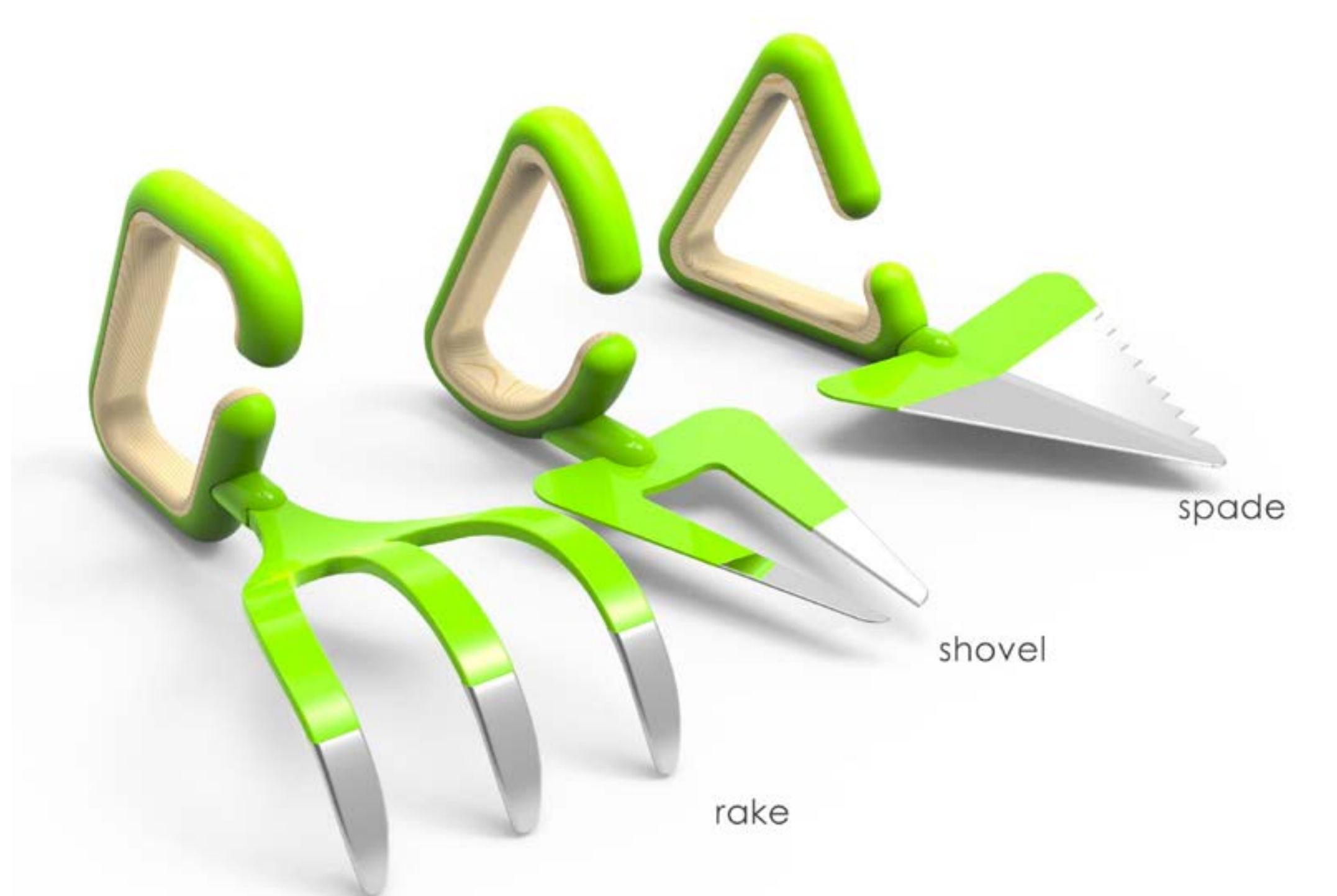

In Issue 7 of 'Squirrel' we highlighted the beginnings of the Suzhou 'dig' project. Masters student Gatsby demonstrates her project development in her designs for children's gardening tools. Her drawings and renders show incredible attention to ergonomic details, material usage, wear resistance and aesthetic appeal.

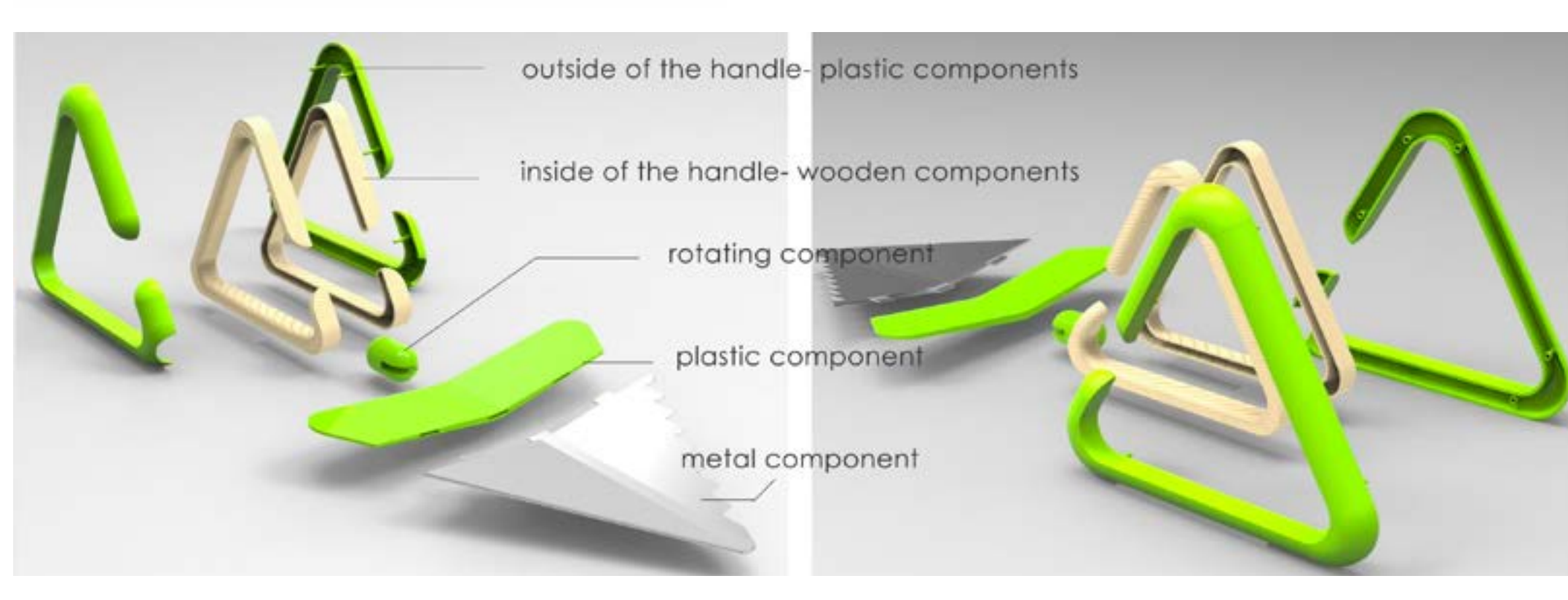

CAREER CHOICE

An education in design can take you in many directions after graduation. Design develops transferable skills you can put to work in all sorts of opportunities.

Both Serena Lee (right) and Carolyn Ang (below) completed Communication Design in 2016, but their careers have taken wildly different paths. **Serena** is Co-founder and Director of 'Farmwall', an agrifood-tech startup that designs urban farming technology and experiences to enhance fresh produce accessibility in the city. **Carolyn** is a communication designer specialising in publication, editorial, and identity design in London.

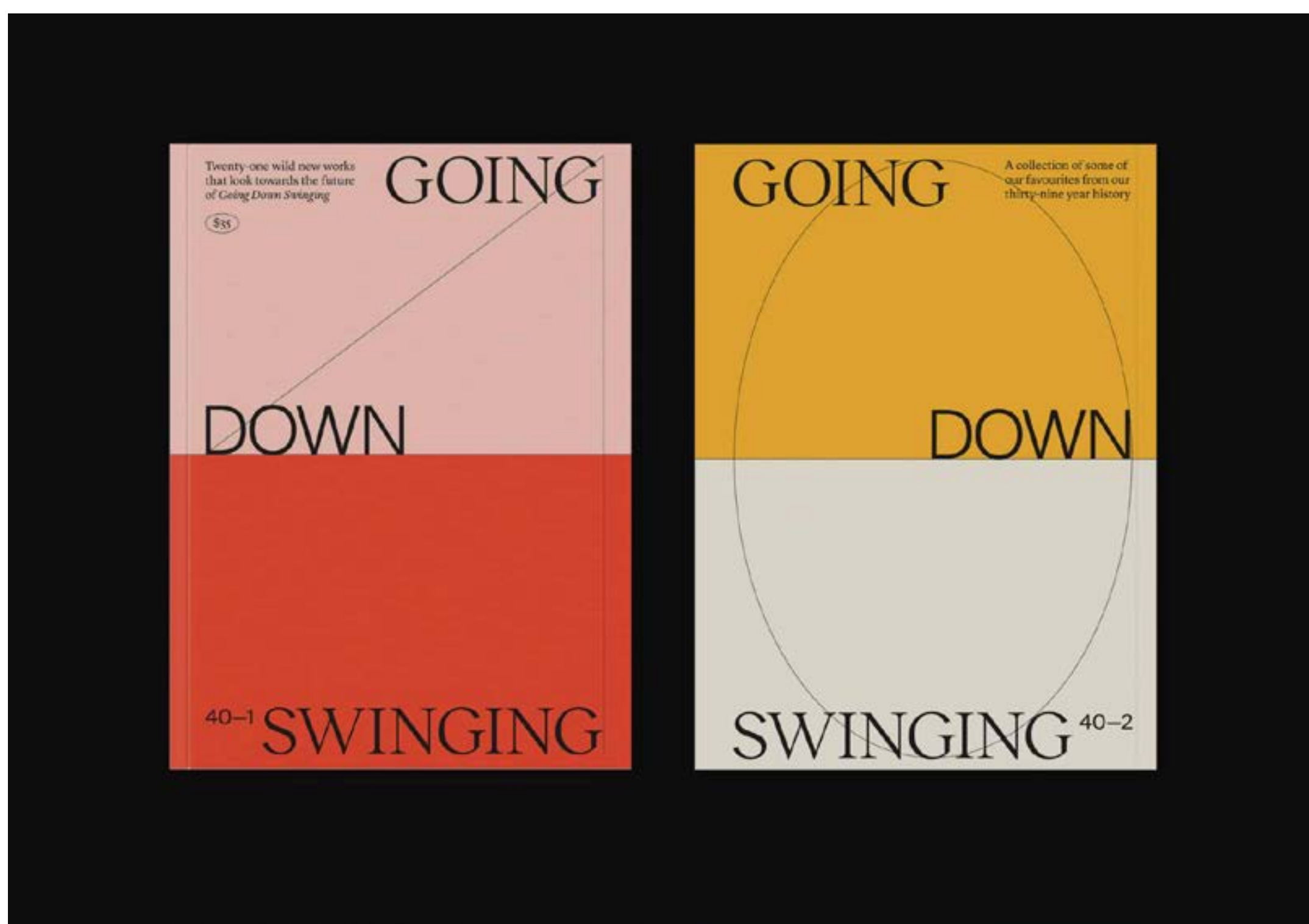

SOUND ADVICE

As a student Carolyn undertook an internship with **Paoli Smith**, a studio established by Monash Alumni Andrew Paoli and Matthew Smith. Here Carolyn learned a great deal and took away some very sound advice from the generous staff who work there, and now we get to share it with you.

- Your voice and your opinion are one of your most important assets as a designer, so never be afraid to speak up and offer your ideas or views, no matter how silly you think they are. Just because someone has more experience than you does not necessarily mean what they have to say is more valid.
- You should never stop learning, no matter how much experience you have.
- Always seek the opinion of others about your work. Sometimes their ignorance of the job can offer a fresh perspective that you might not have otherwise seen.
- Never forget that just because you are in front of the computer does not necessarily mean you are being productive. Time away from the tools is integral to spawning fresh ideas and offering clarity to your work. Do not underestimate the power of fresh air.
- Share your ideas, what could come back to you can be something more wonderful than you could have imagined. It could propel your idea from something good to something great.
- Spell Check. Even if it's not your job, the client will expect you to!
- Read design books – not just blogs. Look at the pictures but read the content also – it can be incredibly insightful.
- If you believe in your work – stand up for it, fight for it (but in an articulate, non combative way)
- Ask questions, ask questions, ask questions!
- If you find something is taking a very long time, ask a more experienced person if there is a shorter way, generally there is.
- Immerse yourself in other worlds, not just design. You'd be surprised how much inspiration they can offer.
- Be enthusiastic, this is your single greatest asset as a junior designer – older designers feed off this and it can bring a lot to the culture of the studio.
- It's not how talented you are, it's how hard you are willing to work.
- Don't be afraid to sell yourself. Practice talking about your best qualities and why you are the most suitable candidate for the job.
- Be nice, be personable. It makes a massive difference, and often is what influences the decision on whether or not you get the job.
- **Design is about ideas and communication, it's not about making things look pretty (even though sometimes it may appear that way). As long as you bring this philosophy to every project you undertake, you can't go wrong.**



Illustration for narrative
Lecturers: Ned Culic
 Tracie Grimwood
Project: 'Boxaphobia'

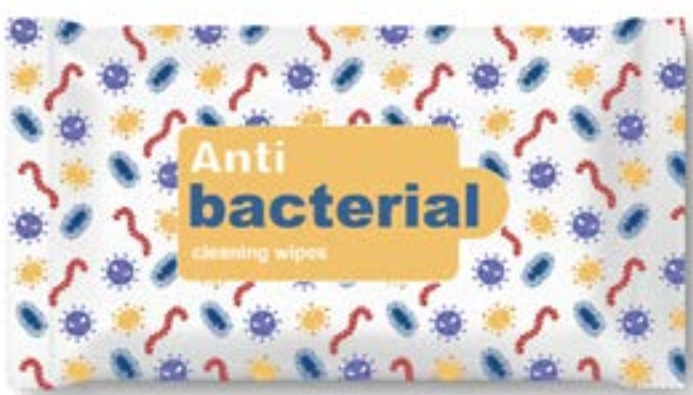

Clockwise from top:
 Entomophobia (fear of insects):
 Bree Mitchell (Communication Design)
 Heliophobia (Fear of the sun):
 Tiff Nicholls (Communication Design)
 Pyrophobia (fear of fire):
 Anna Kwong (Architecture)
 thaasophobia (fear of sitting or idleness)
 Lexi Liu (Communication Design)
 Mysophobia (fear of contamination or germs):
 Zihan Lin (Architecture)

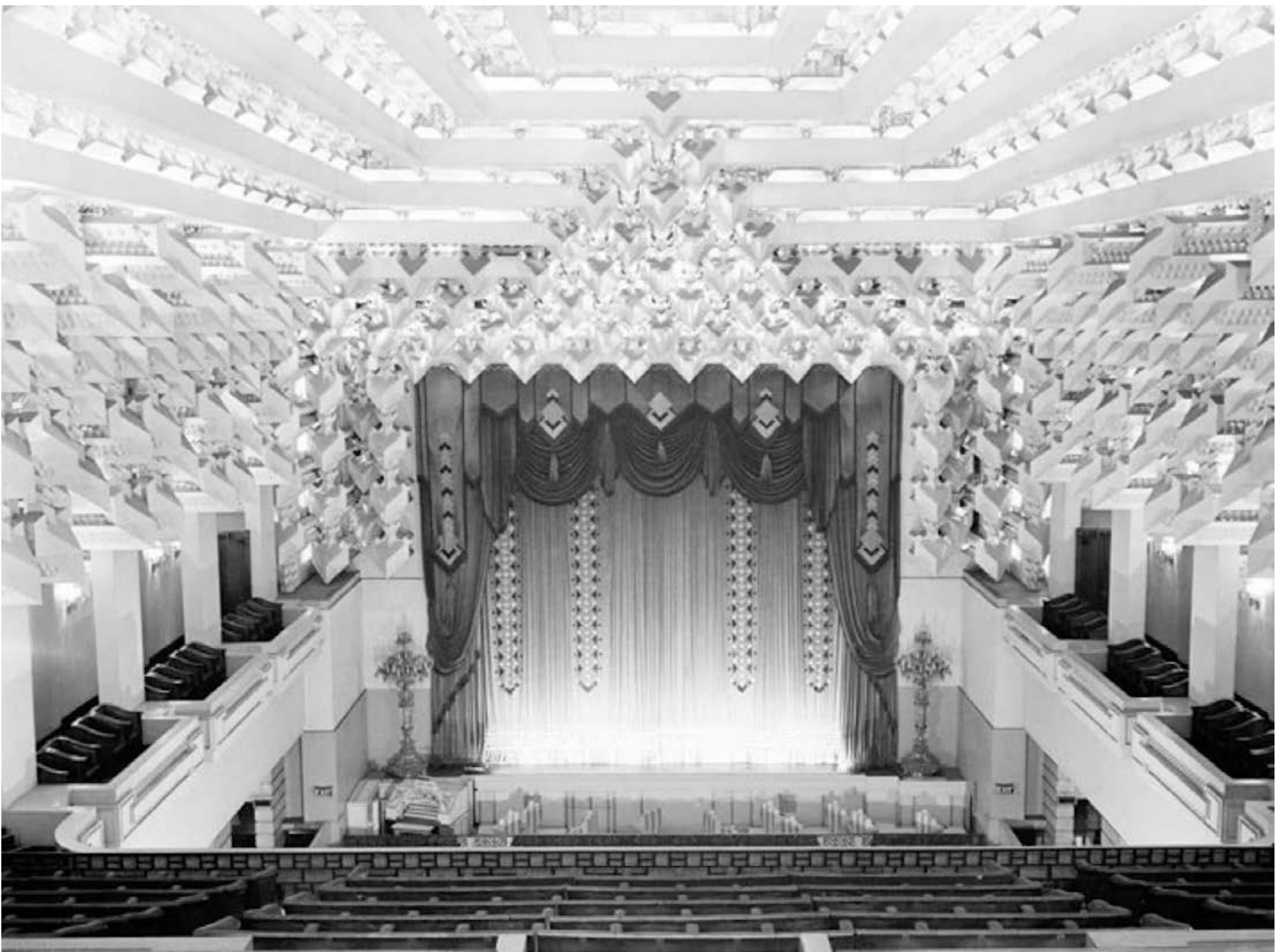

Open House Melbourne is an independent organisation that fosters public appreciation for architecture and public engagement in conversations about the future of our cities. This year their iconic 'open weekend' which gave the people of Melbourne an opportunity to see inside some of the cities best buildings will shift online. Join them for a digital celebration of architecture and our city on the weekend of July 25 and 26.

Tap the Open House icon, left, to connect to their and sign up for notifications about the weekend.



Tap the image of the Capitol Theatre, above, to connect to the previous OHM talks, including Peter Malatt (above), speaking about restoration of the Bourke Street theatre

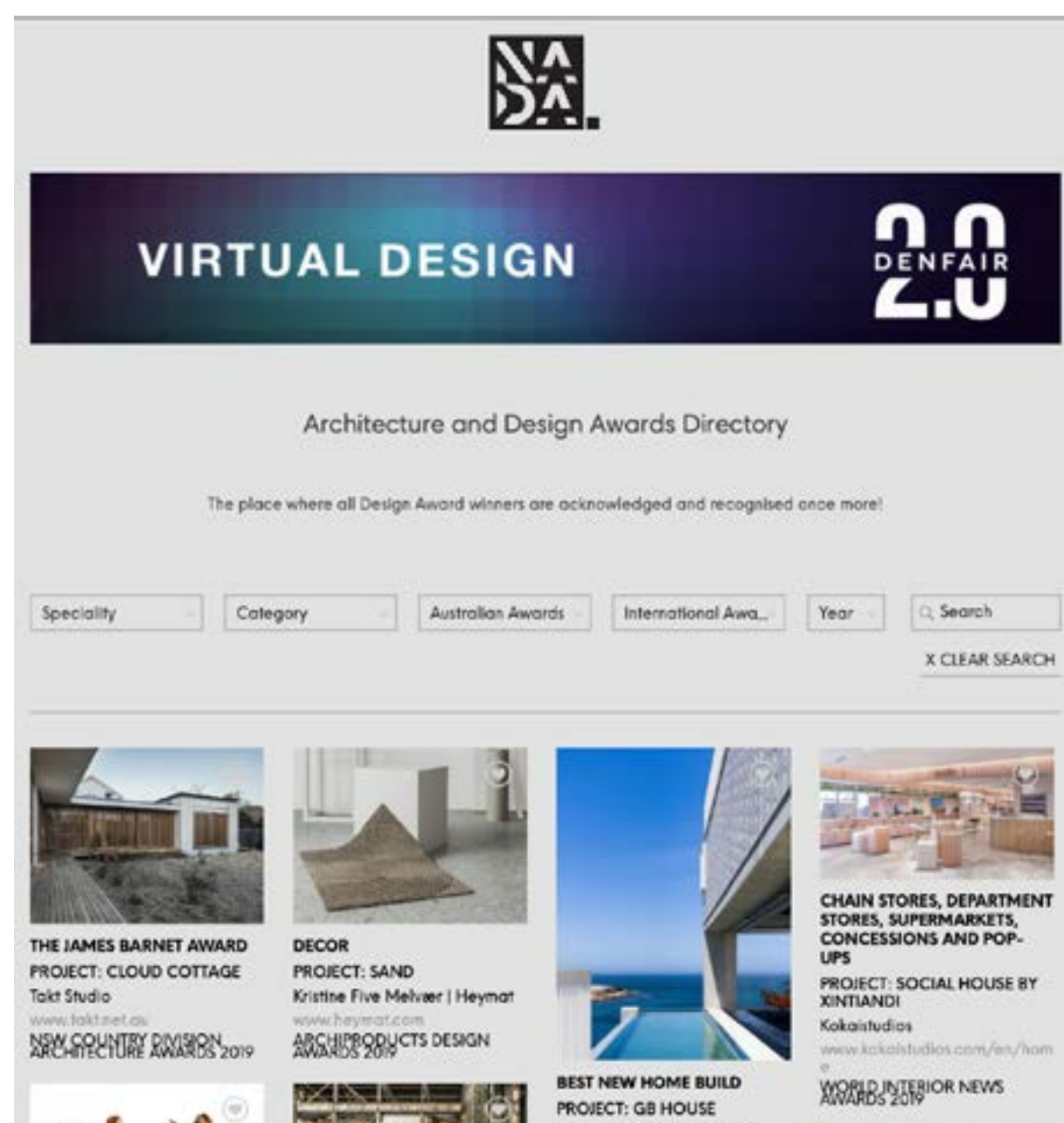

Not another Design Award

In the spirit of inclusion, NADA (Not another Design Award) is here as a neutral platform that celebrates all awards programs and their winners.

There are upwards of 30 design awards programs in Australia alone. And yet, no cross-platform database that charts them all... until now.

Find every awarded project, product, innovator and creative right here, searchable by studio, speciality, award category, location and year in a totally unbiased platform.

Just tap the image to connect



The Book Grocer

The Book Grocer Online offers a broad and ever increasing range of discounted remainder and secondhand books. The first Book Grocer in Victoria opened in Brunswick. Book Grocers can now be found in a range of locations across Victoria, New South Wales, South Australia and Canberra. Their specialty is sourcing discounted books of amazing quality. They scour the globe and the best publishers and suppliers for the best bargains, but no book arrives in their warehouse simply because it's cheap. It has to be something they want to read themselves and recommend to others. For those who enjoy graphic novels they have a particularly large supply.

Tap the book to connect to the store



You may recognise a few faces in the Zoom Room this week, because a number of them are in your classrooms as well. But, when they're not there they're working on design projects and research. Here we see Chris, Desiree, Anna, Ilya, Hannah, Gyungju and Melisa collectively inspiring each other to articulate ideas into words in their 'Shut up and write' workshop. The typing technique looks a little Nosferatu, but I'm certain the intellectual productivity was entirely Hermione Granger.

For those squirrels old enough to remember Jim Henson's Muppet Show (1976 to 1981) there's a strange familiarity between the show's opening sequence and the large Zoom conference calls we've made many times over the last 3 months. But this Zoom seems much more fun...

It's time to join the meeting
It's time to start the mic
It's time to start the camera on the millionth Zoom tonight
—@LauraRoseMills



Inclusive Communities: Queer 101 online training



Monash Inclusive Communities is excited to announce that Queer 101 is now available as an online module in Moodle.

Queer 101 has been a staple diversity and inclusion initiative at Monash since 2014. The new online format provides everyone the opportunity to learn more about the LGBTIQ community and how to support their friends and peers.

Sign up for the training to learn more about sex, gender and sexuality!

You'll be empowered to create positive change for LGBTIQ people in your communities.

The training covers:

- the basics of the LGBTIQ acronym
- how gender identity and expression function in society
- some of the key issues faced by the LGBTIQ community including the gender binary and heteronormativity

Access the training at monash.edu/queer-101 or just tap here.



Weird or wonderful

Run out of things to watch on Netflix? From the depths of their archives, the Australian Centre for the Moving Image (ACMI) have pulled together the very best of their collection into one weird and wonderful Youtube playlist. From instructional videos on personal hygiene to warnings about wayward youth, this collection is both compelling and bizarre. Included in the playlist is 'A hundred odd years from now'; an advertising film that features a strange computerised future where women "run things" by controlling huge colourful cardboard computers. Their lives are eventually disrupted by Yockoo, the boy from the bush, with his satchel of dried fruits. Music by Frank Smith, Photographed by Lars Gundlach, Written and designed by Weatherhead & Stitt.

To view the full playlist just tap the image.



While this is the last Issue of Squirrel as you know it for Semester 1, there will be another edition out soon. The **Design Honours** students are taking the editorial reigns for a special issue that features the work and research they've been doing for the last semester. Stay tuned.



Precious Plastics 2020 Injection Mould Design Competition

is a collaboration between Precious Plastic Monash and the unit IDN3001 (Materials and Manufacturing component). This competition gives designers the opportunity to turn their CAD designs into real products through the use of CNC milling and injection moulding.

Precious Plastic Monash designs products that are functional, interesting, cause delight and represent quality. The submissions will be judged on these criteria.

Submissions due: 5:00 on Friday 10 July 2020.

For more details tap the 'comp' icon.



Teaching Associate Anna Conrick initiated a brilliant move to help our first years learn online: the Collaborative Design YouTube channel.

Over the semester the teaching staff of COL1001 took to the screen to offer project feedback, and talk about everything from materiality and making, to documentation and curation. A great learning resource worth sharing. Just tap the image, right.





The last word

Thank you hardly seems powerful enough a term to acknowledge the amazing effort put in by everyone involved in the delivery of the Design units in Semester One. As awful as COVID-19 has been, it has driven many of us to play our A game; to think innovatively about how we learn and engage with design, and in ways we would never have thought of before being challenged in the ways we have. We have seen videos and podcasts used to create content and assessments; Instagram as a means to share studio work that otherwise would not be seen; Zoom as a consultation device; jamboards as a collaborative tool... Indeed 'Squirrel' wouldn't exist without the impetus of COVID-19. But we do look forward to seeing people back on campus next semester. The spontaneous engagements, the spirited conversations, and the genuine and lasting friendships, are a vital part of our learning experience and as important as the content that occurs in classes. So, on that note **THANK YOU** to everyone: the fulltime and associate teaching staff who coordinated the impossible and successfully turned their delivery to online with four days notice; the professional staff who supported us and helped manage many parts of your learning experience; and of course you the students, whether here or overseas who stuck with us and proved that creativity and ingenuity cannot be stifled by the likes of a pandemic lockdown. Good luck, and stay well; that well-deserved break is now truly in sight. – **Gene Bawden**, Head of Department, Design